



surfbee.io

Table of Content

WHAT?

Introduction	2
Equipment Overview	5
Vessel Assembly	7
Controller Functions	17
Launch Checklist	21
Warranty Information	34

Please Read Before Operation

WHAT?

HOW?

Batteries DeWalt 18V

Ensure that batteries have the same capacity and charge state, mixing different battery capacities and battery charge state can damage them, e.g., do not use a DeWalt 9 Ah battery with a DeWalt 12 Ah.

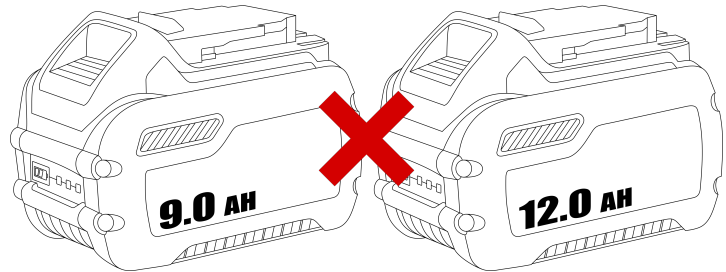
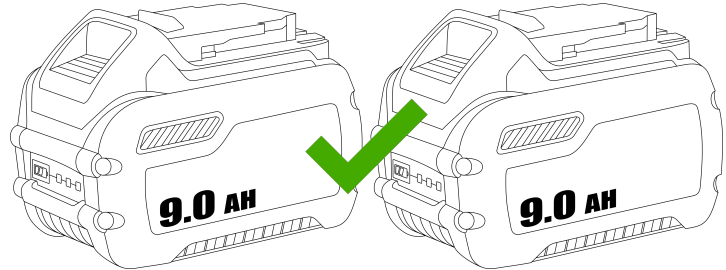

Avoid using a fully charged battery with a discharged battery to prevent damage.

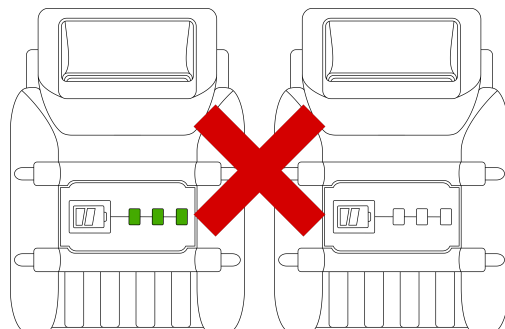
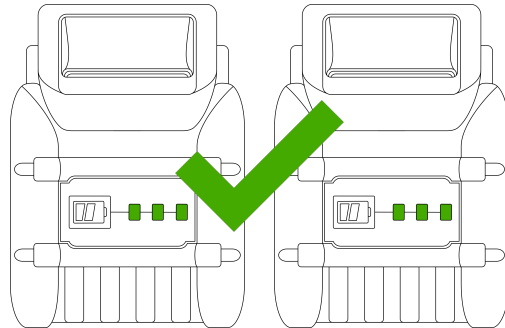

WHAT?

HOW?

Thrusters

Avoid running thrusters for extended periods without being immersed in water. Overheating may damage the motor if operated out of water.

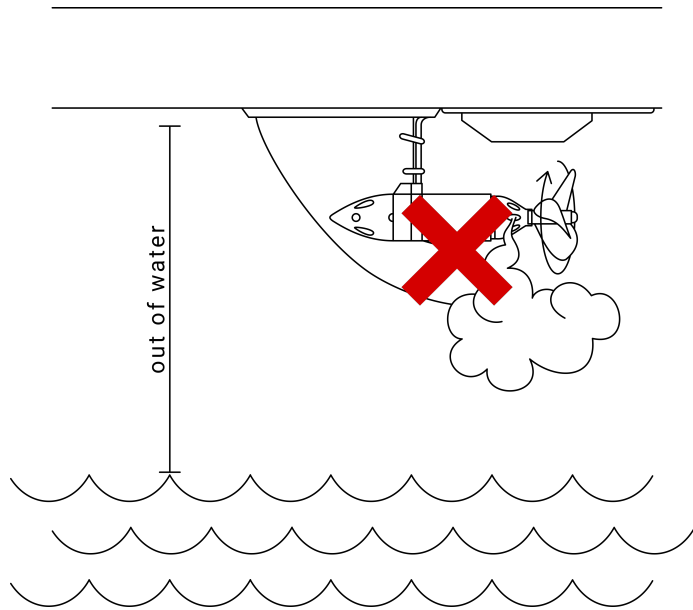

Check for debris around the motor; any obstructions may strain the motor and accelerate wear.

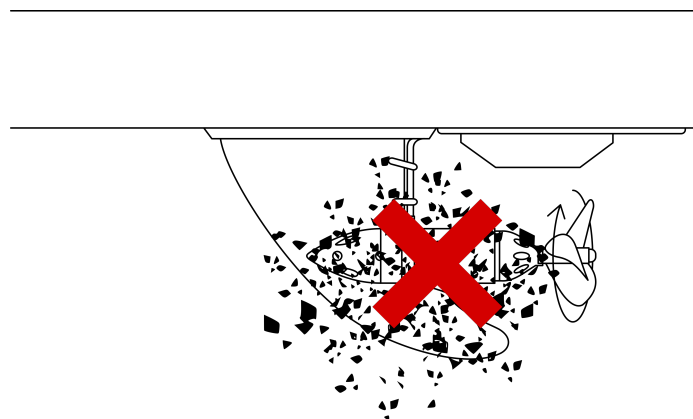

After operating in salt or turbid water, flush the thrusters with fresh water for 2 minutes to prevent corrosion.

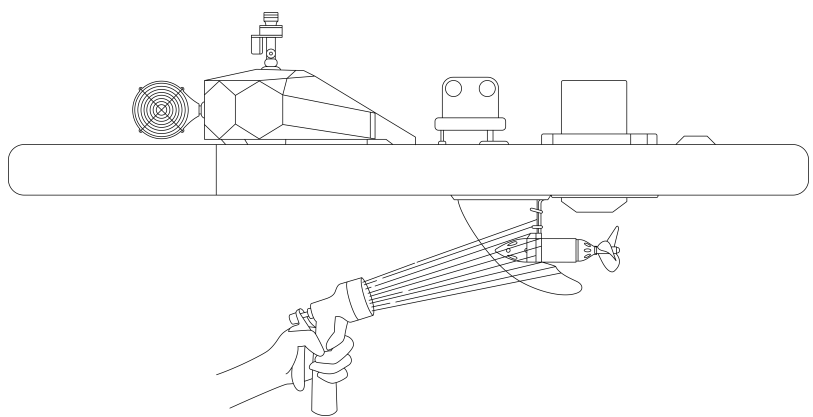

WHAT?

HOW?

Maintenance

Before operating the vessel, ensure all bolts and mounting hardware are securely tightened.

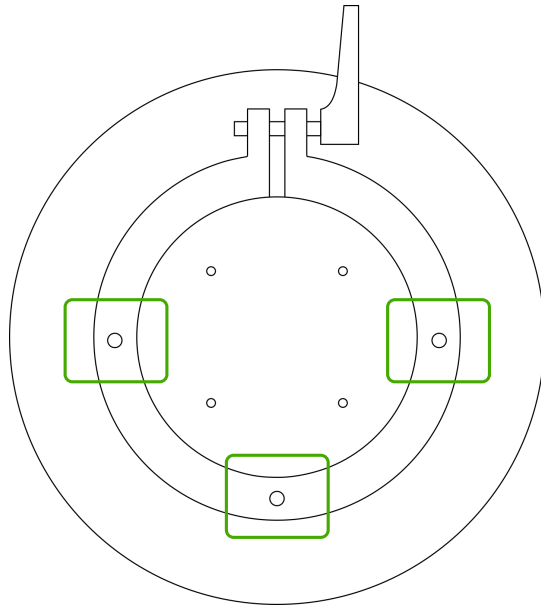

Routinely apply corrosion inhibitors on all screw threads on Surfbee enclosure if operating in saltwater to prevent rust and corrosion.

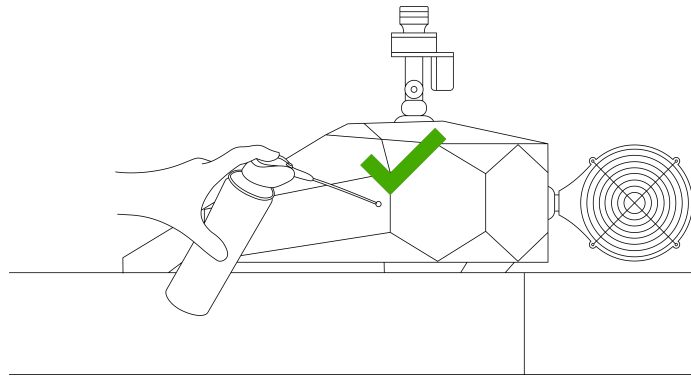

Equipment

Flow Series

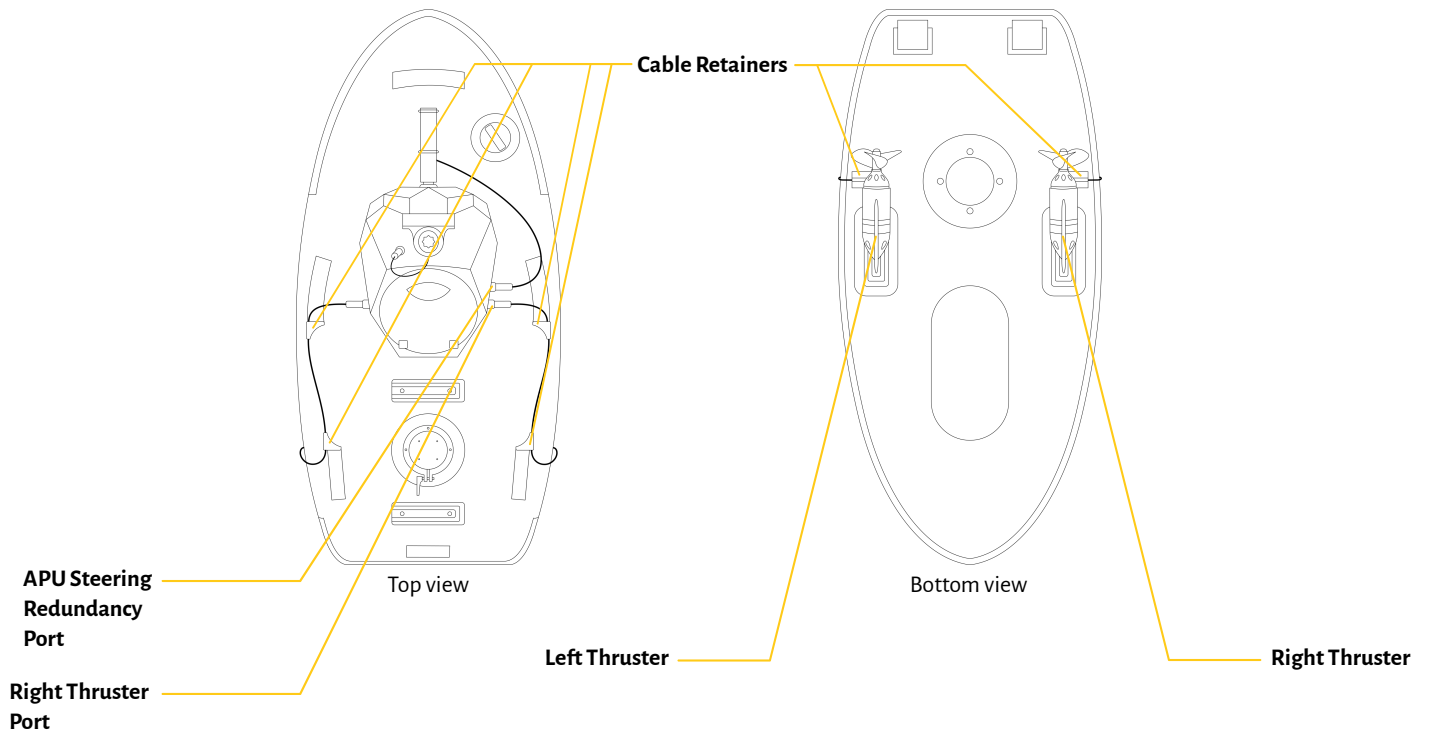
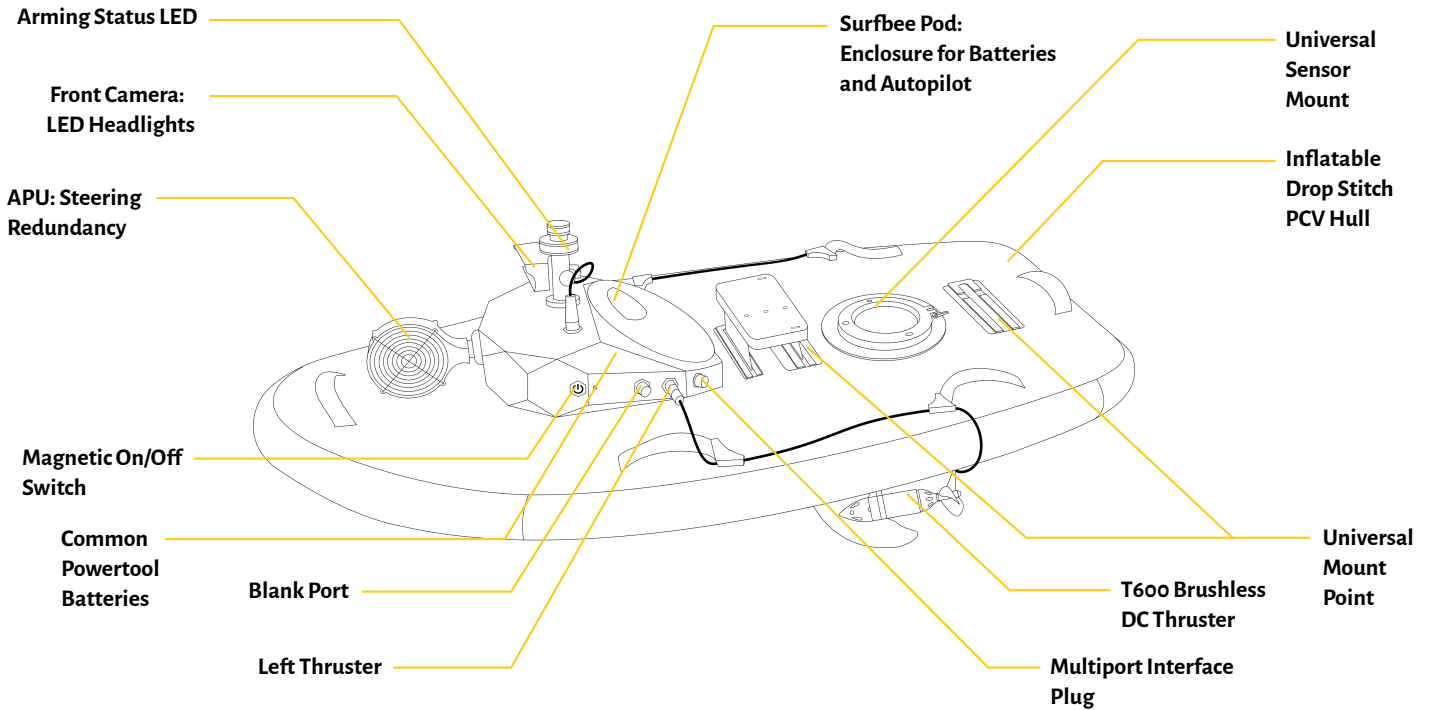

Equipment

App

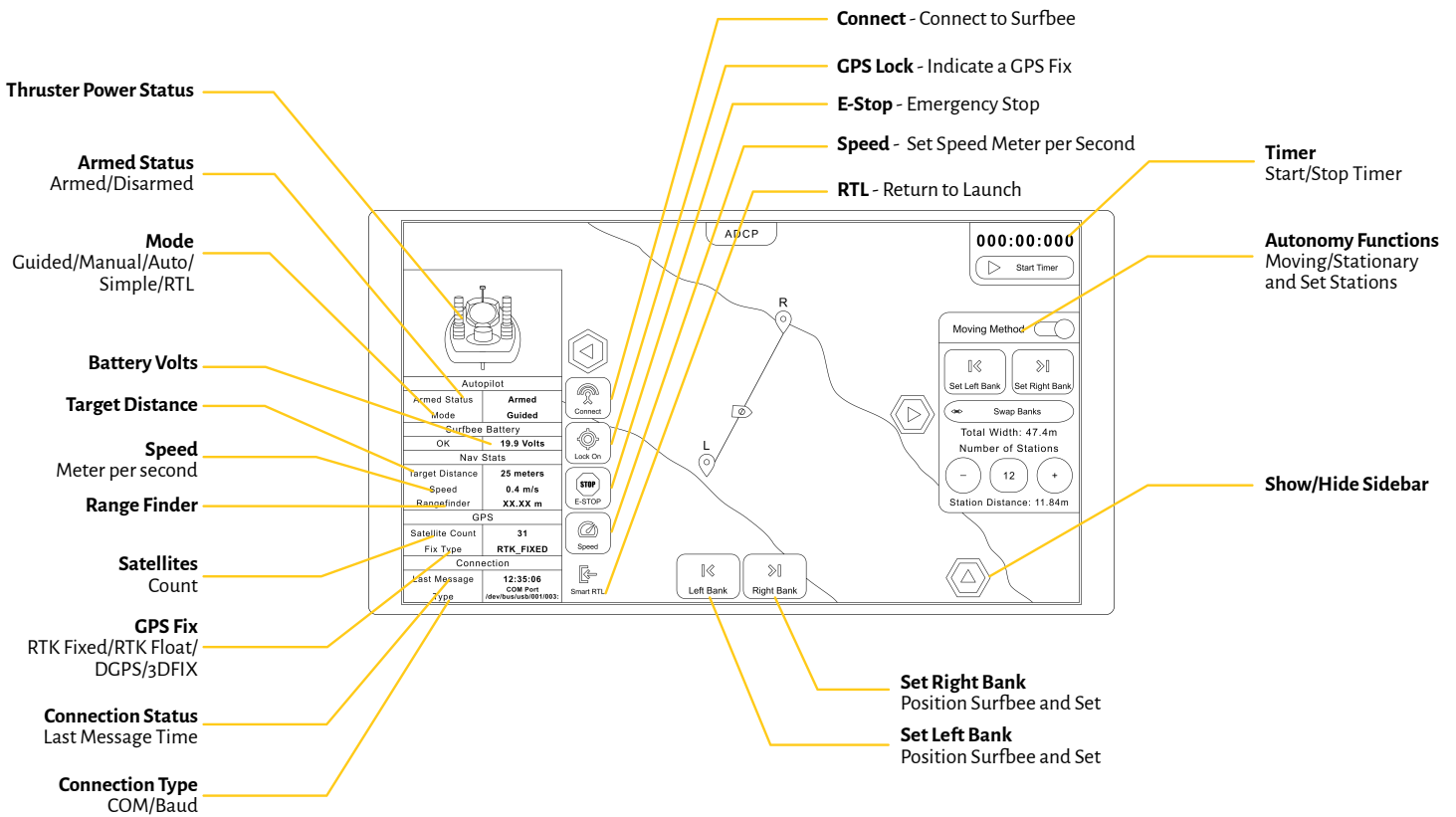

Controller

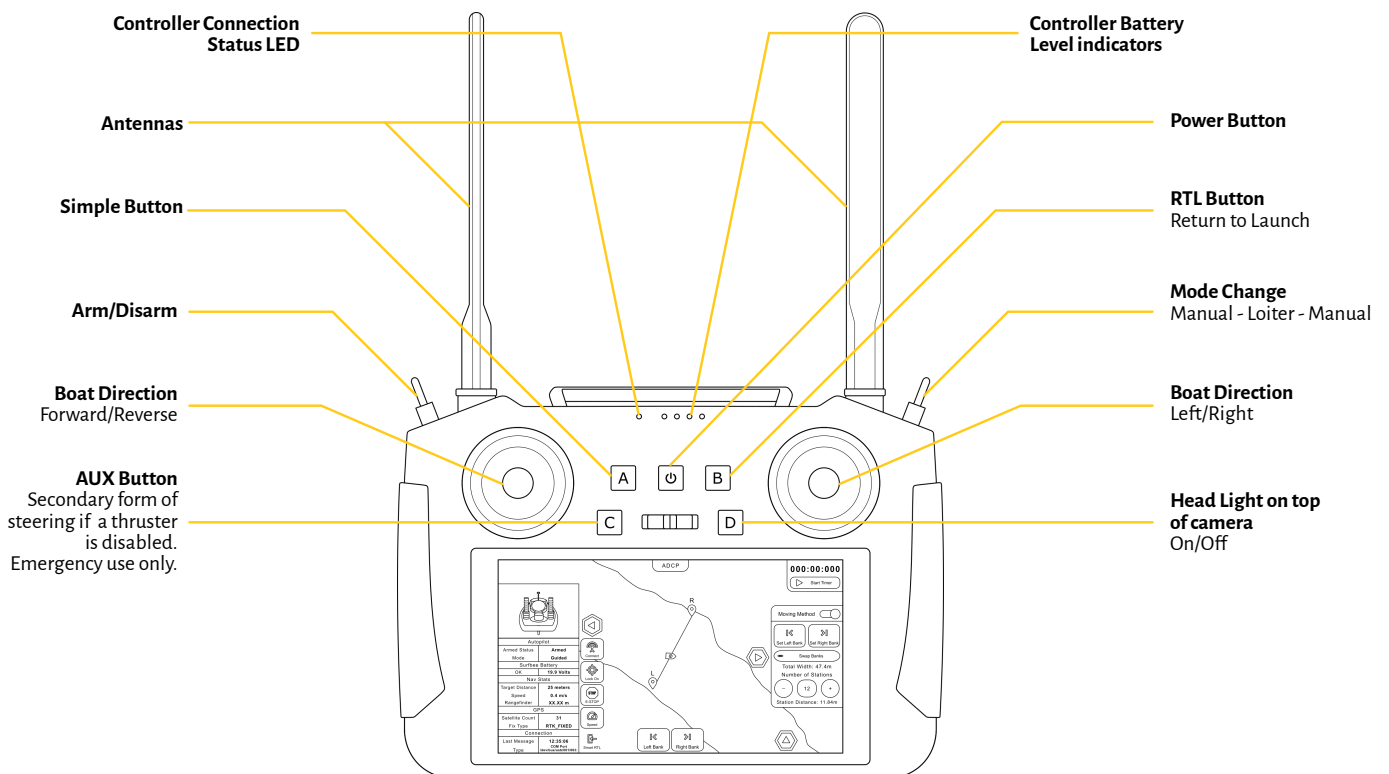

Assembling Your Surfbee Flow Series

WHAT?

HOW?

Inflate Your Vessel's Hull

Before fully inflating your vessel, partially inflate it to provide just enough rigidity to insert the yellow plastic pod into the designated compartment. Ensure the pod is positioned as illustrated in the provided image.

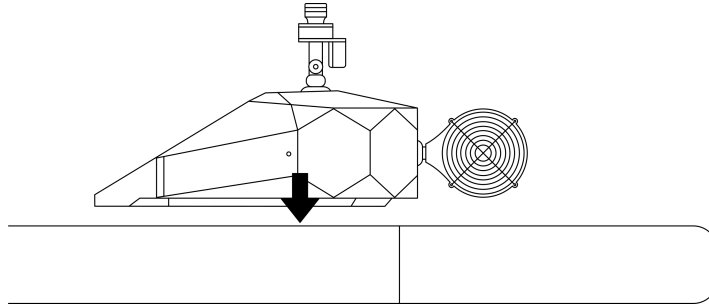

Once the pod is securely in place, continue inflating the vessel to the correct air pressure (9psi minimum). This process ensures that the pod is firmly secured by the pressure of the inflated vessel, maintaining stability and buoyancy during operation.

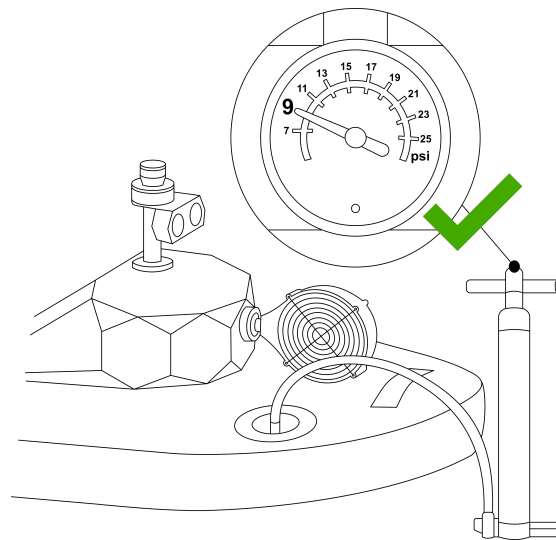

Attach the Mounts to the Vessel

Attach the mount to your vessel by connecting the bolts as the image shows.

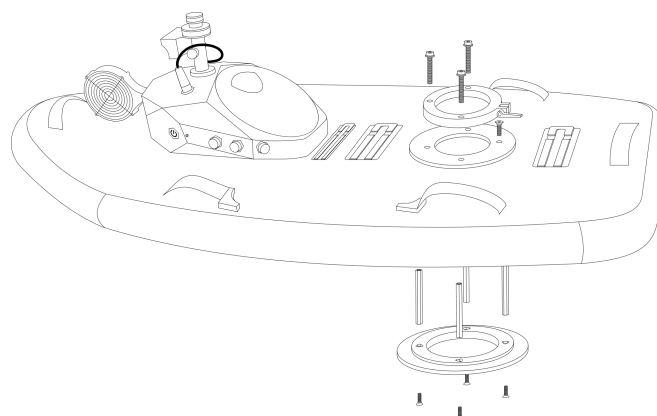

WHAT?

HOW?

If your sensor requires an adapter, connect the adapter to the mount first. Then, insert your sensor into the mount and tighten the bolts to secure your sensor to the vessel.

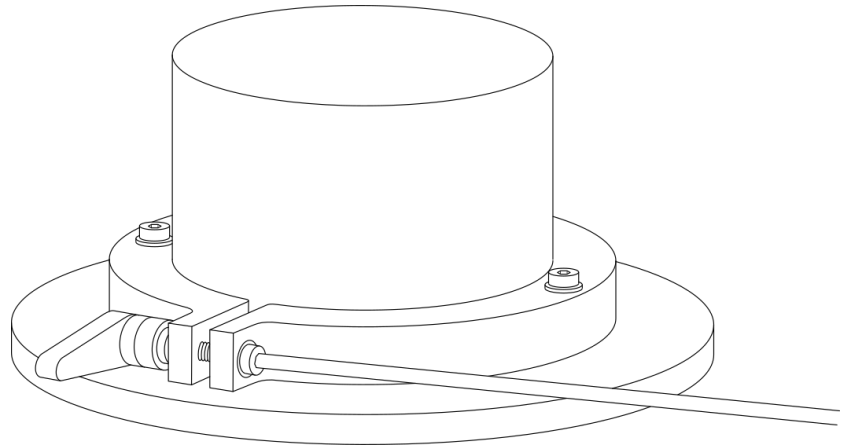

Attaching the PCM Mount

Attach your PCM to the PCM Mount (if required by your sensor), connecting the bolts as the image shows.

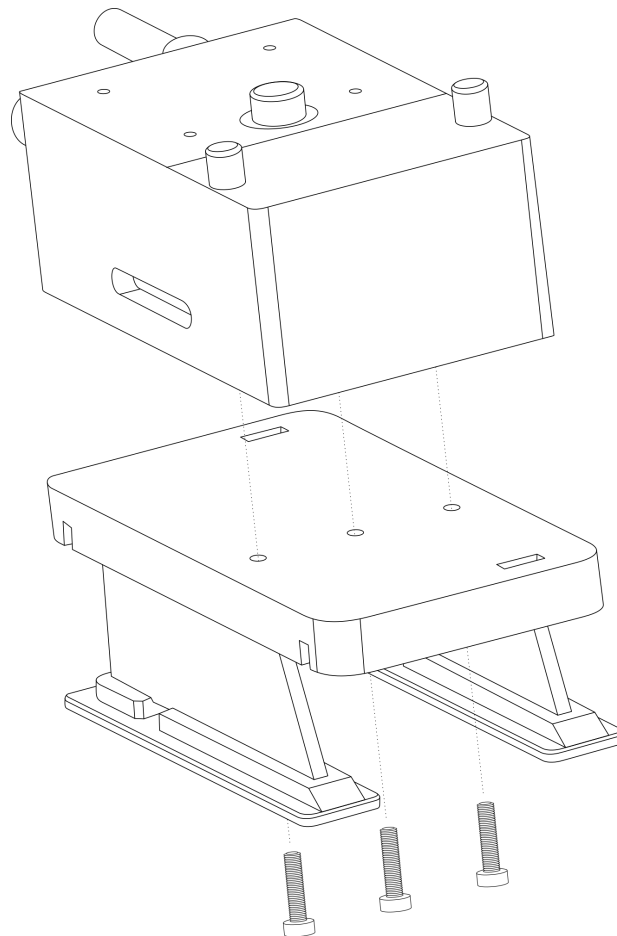

WHAT?

HOW?

Then, slide the PCM Mount into one of the 2 universal mount points located on the top of your vessel.

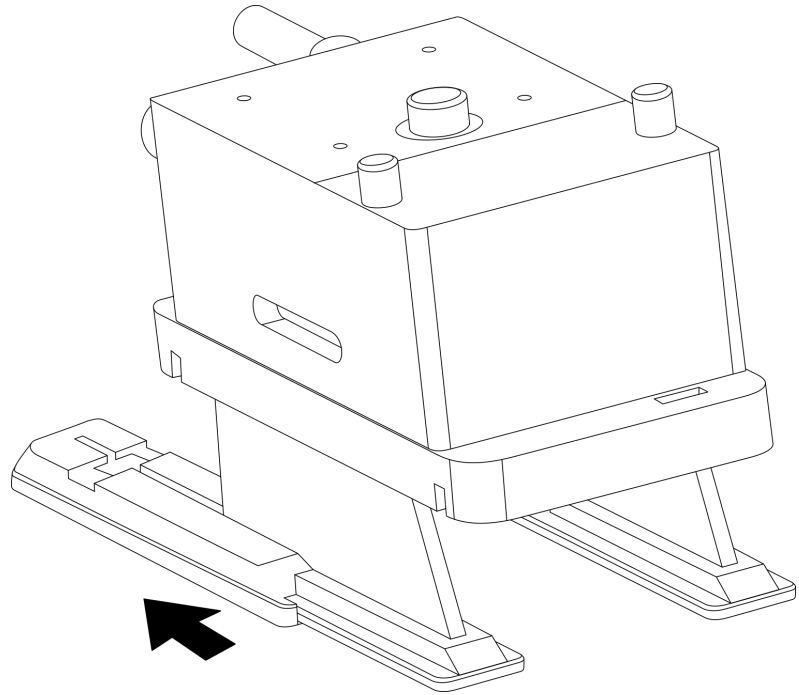

After that, insert the safety lock to secure your PCM.

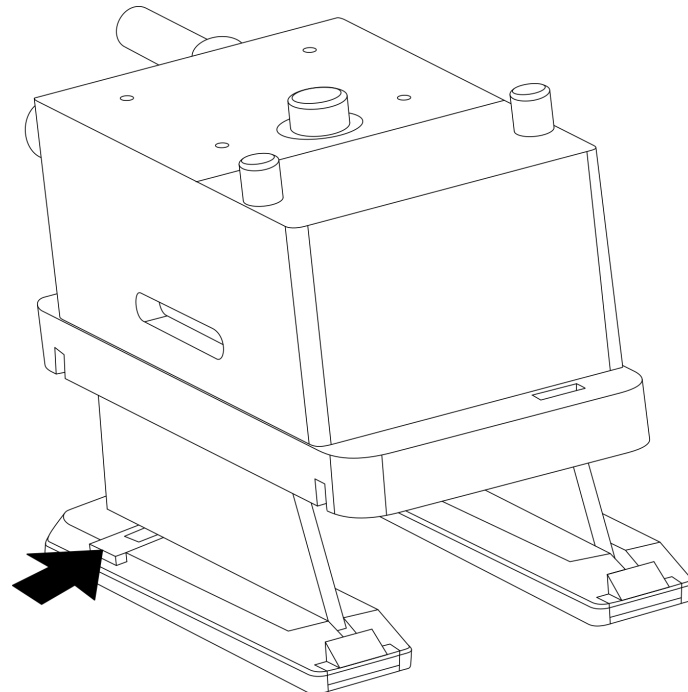

WHAT?

Connect the Front Camera

HOW?

Attach the Front Camera to the top part of the plastic pod.

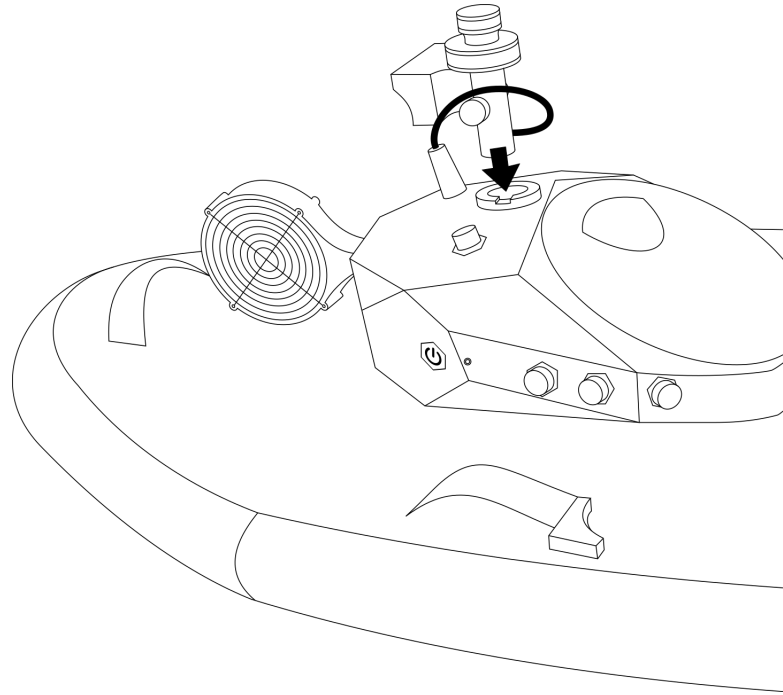

Then, slide the grey lock to secure your camera to the vessel.

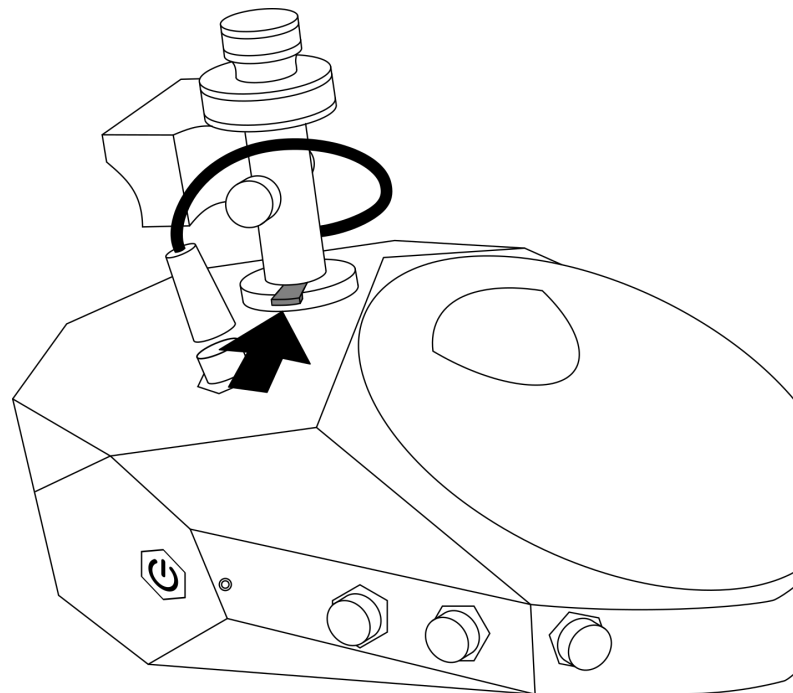

WHAT?

HOW?

Once your camera is attached and secured, connect its cable into the port located on the top of the plastic pod.

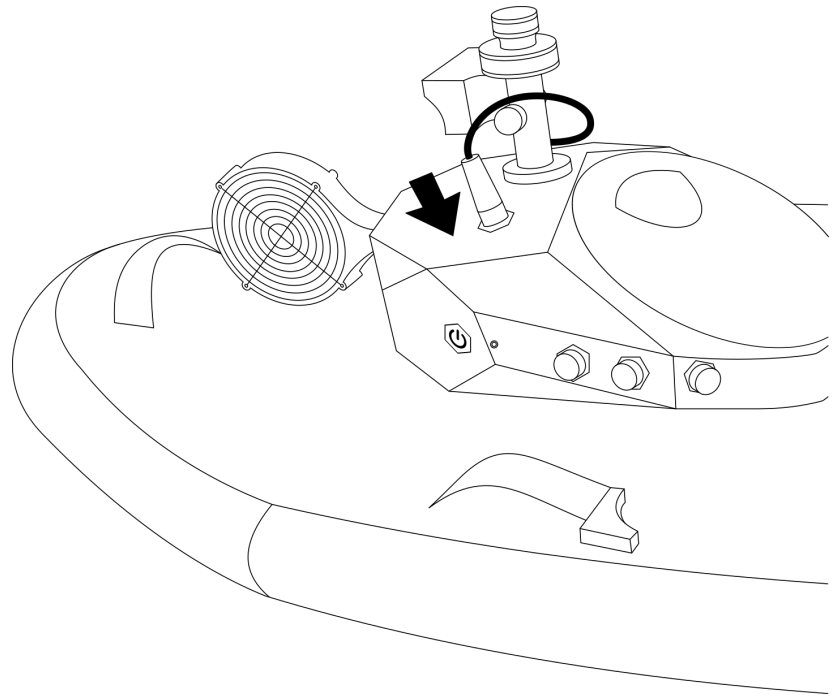

Connect the APU Steering Redundancy Fan
(Only for the Flow Seeker)

Insert the Redundancy Fan into the front part of the plastic pod of your vessel.

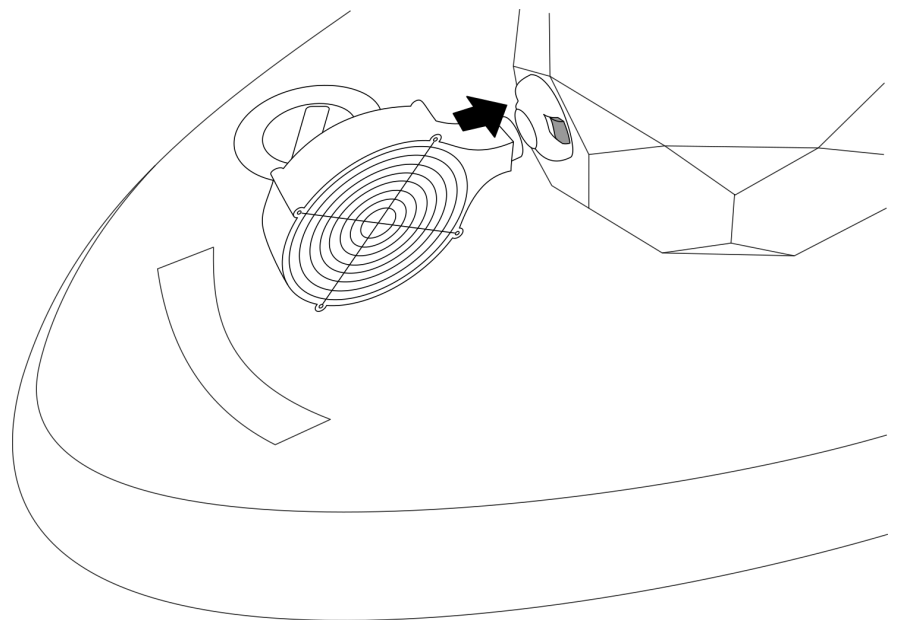

WHAT?

HOW?

Then, slide the grey lock to secure it to the pod.

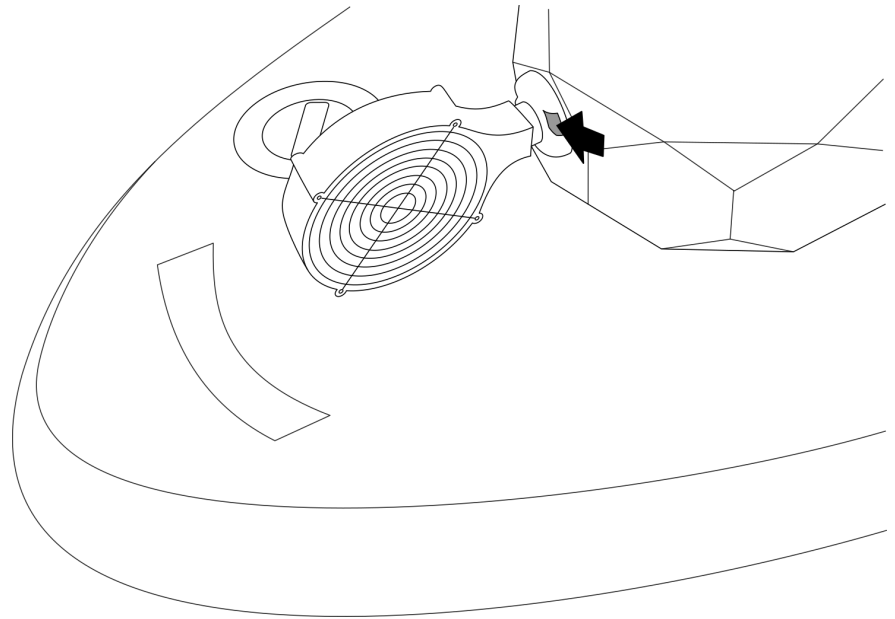

Once the fan is fully attached and secured, connect the cable into the front port located on the right side of your vessel.

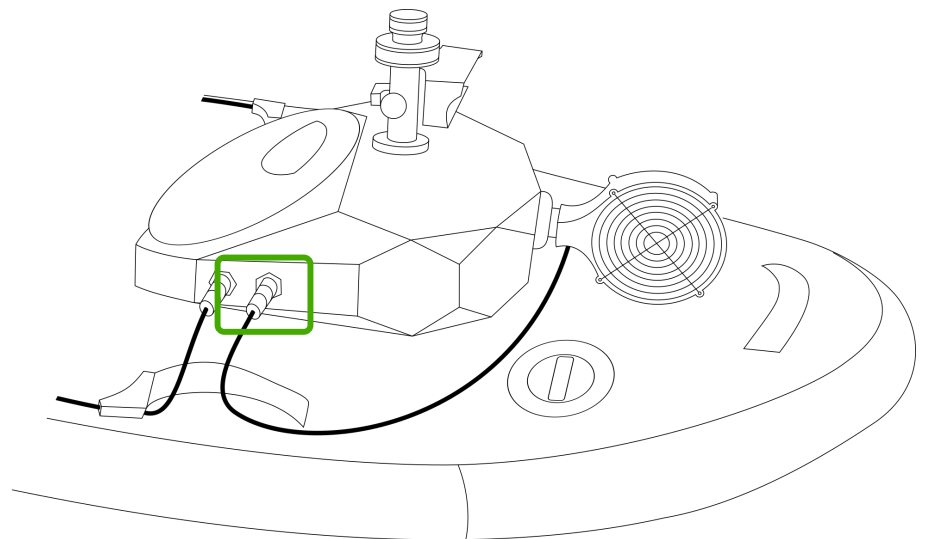

WHAT?

Connect the Multiport Cable to Your Sensor

HOW?

Connect the multiport cable to the Multiport Plug located on the left side of the plastic pod of your vessel.

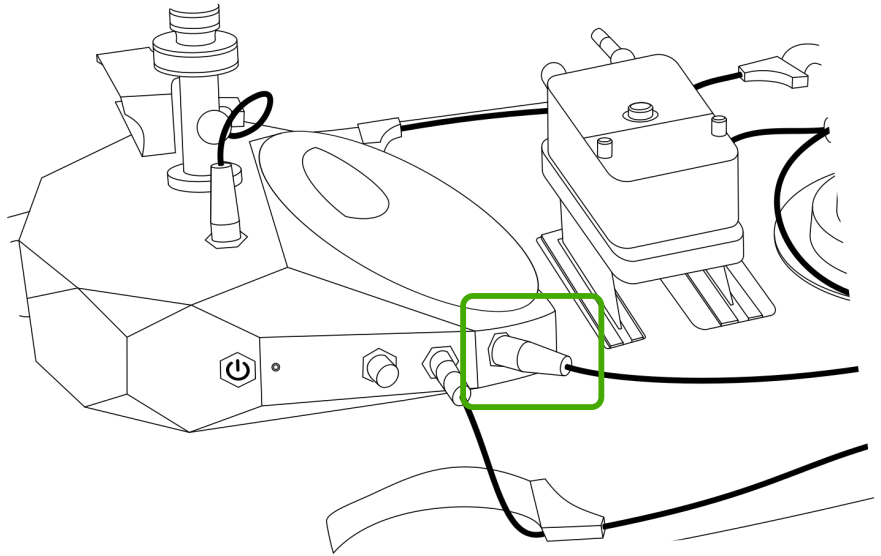

Then, connect the other side to your sensor.

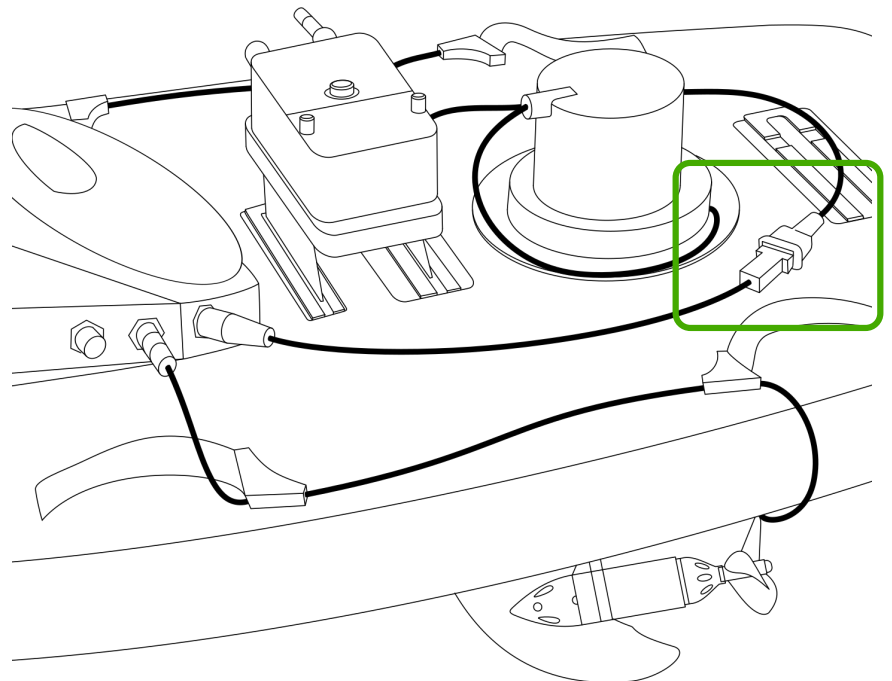

WHAT?

HOW?

Connect the Thrusters Cables

Connect the blue thruster cable (Left Thruster) into the left side of the plastic pod.

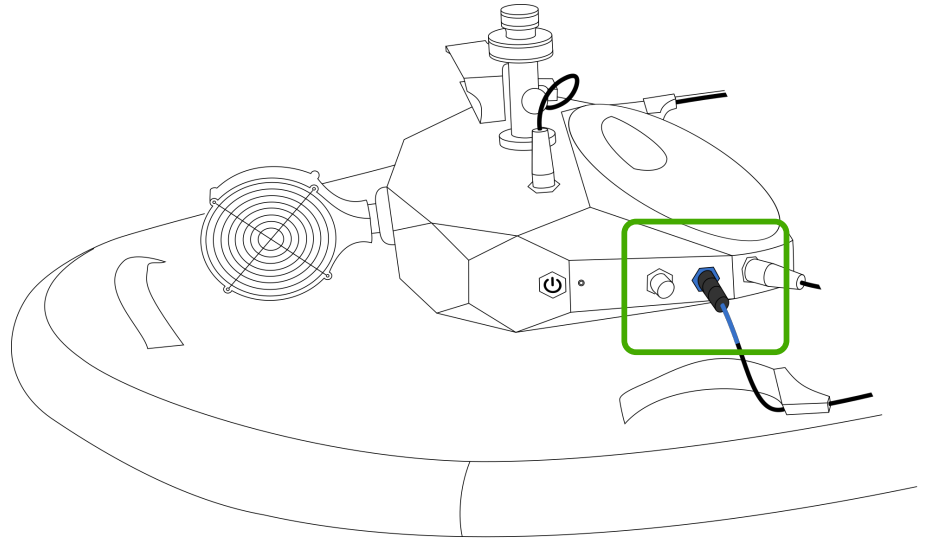

Connect the black thruster cable (right thruster) into the right side of the plastic pod.

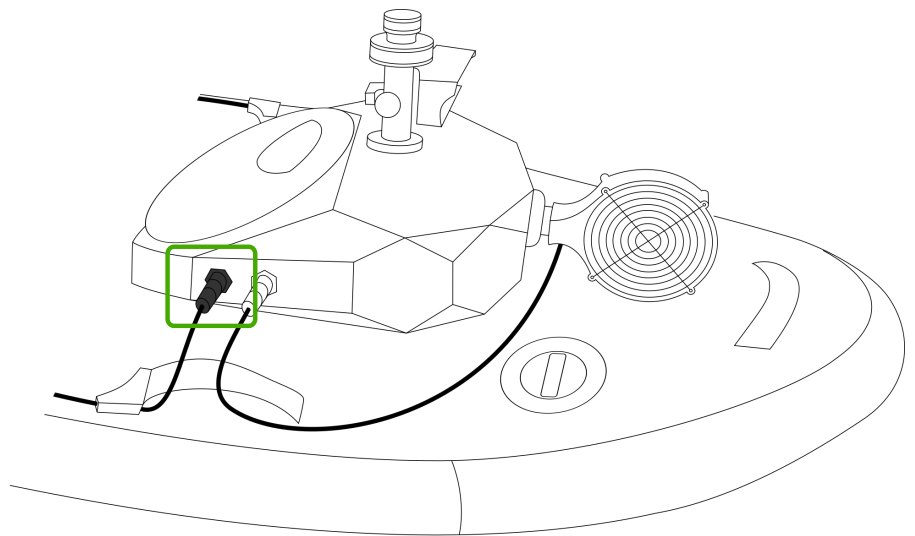

Prepare Your Vessel for Transportation

For convenient transportation, you have the option to leave this section for the specific site where you intend to use your vessel. Simply leave the thrusters connected as described in the previous step and position them on the top of the vessel, allowing for easy connection and portability when needed. See the image below for the correct transport positioning:

WHAT?

HOW?

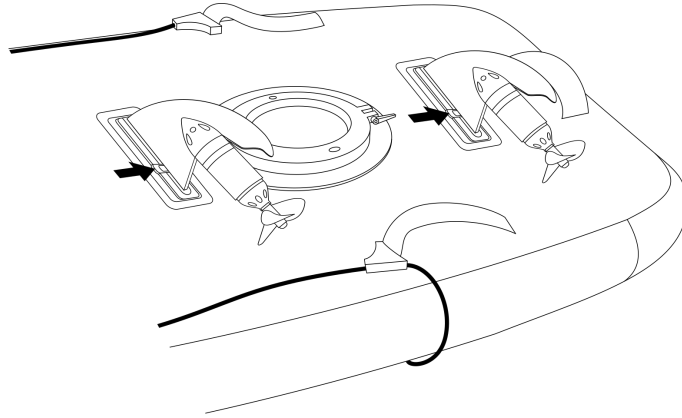

Attach the Thrusters

Slide each thruster, on its respective side, into the mount located in the bottom part of your vessel.

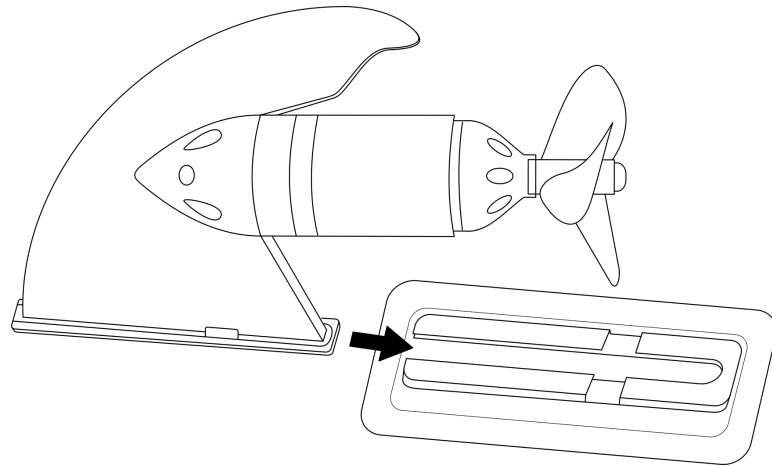

Then, slide the safety lock to secure your thrusters.

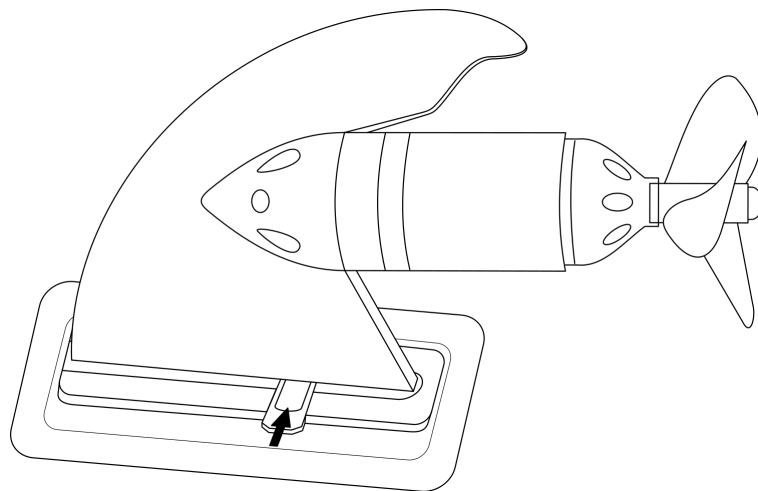

Securely fasten your thruster's cable and affix them to their respective retainers. Begin by fastening the bottom connections and then the top ones, ensuring that no loose cable ends are beneath the vessel.

WHAT?

HOW?

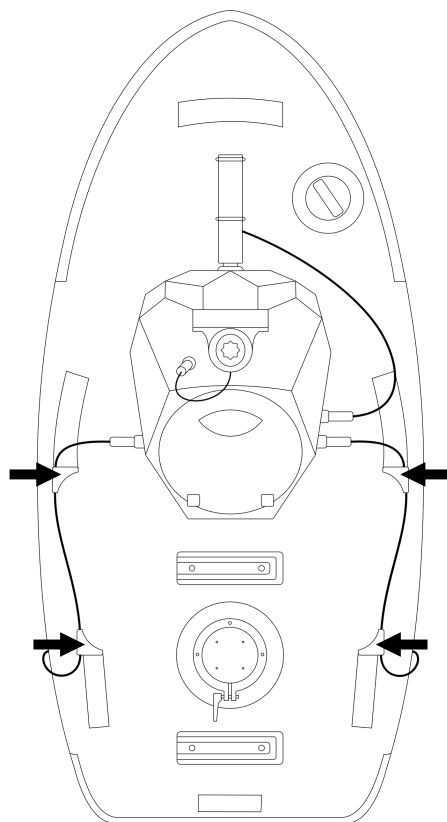
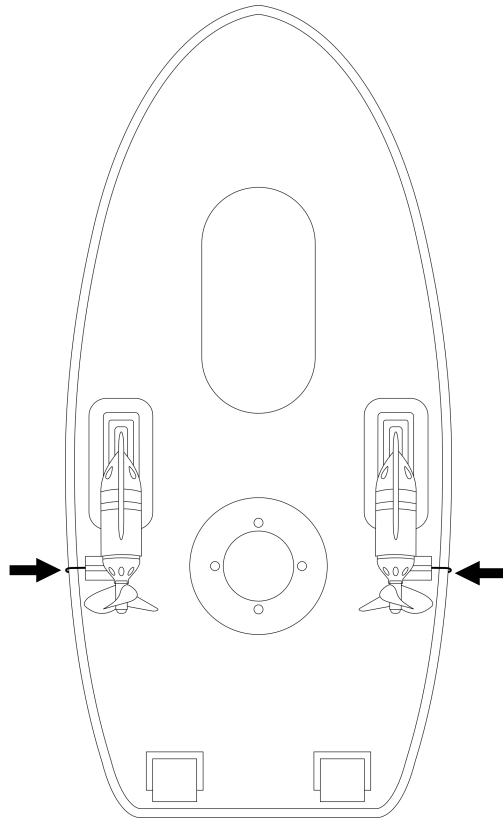

Controller Functions

Controller Functions

Arming Switch

Activates Surfbee thrusters and sets RTL (Return to Launch) location. Wait 90 seconds after power on before arming to allow autopilot GPS to gather location data. The vessel must be armed to operate.

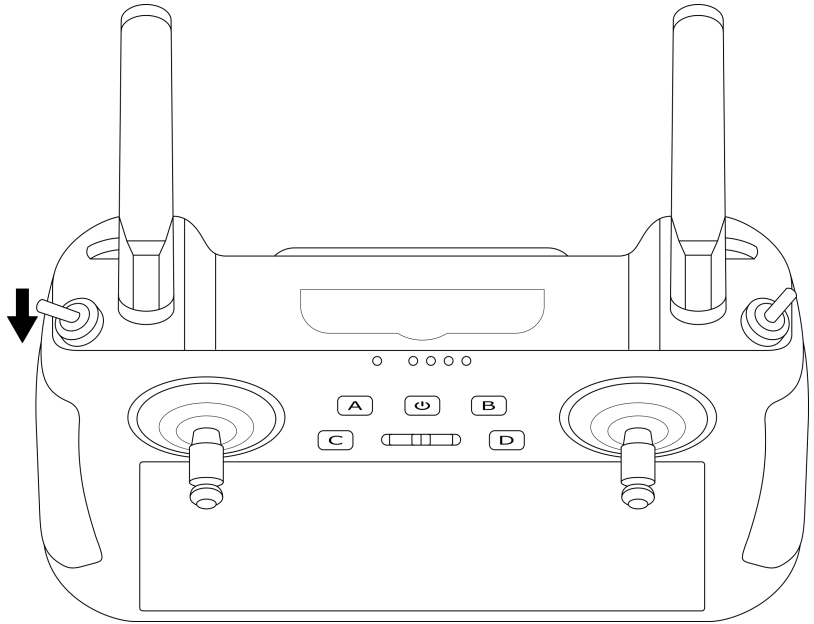

Disarm Switch

Deactivates Surfbee thrusters. Use this mode for transporting the vessel between the vehicle and water.

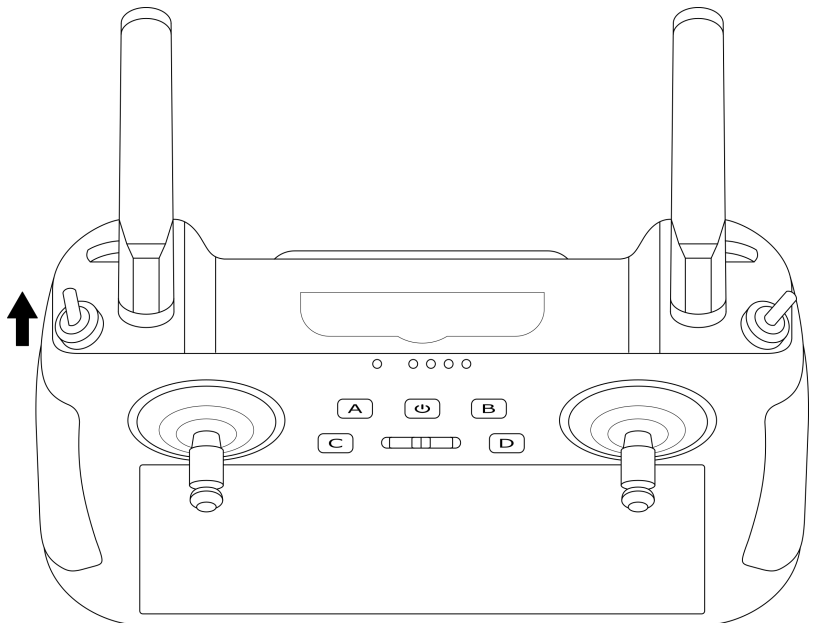

Loiter

Autonomously holds the Surfbee's location when activated. Be cautious, as activating on land may cause the thrusters to engage.

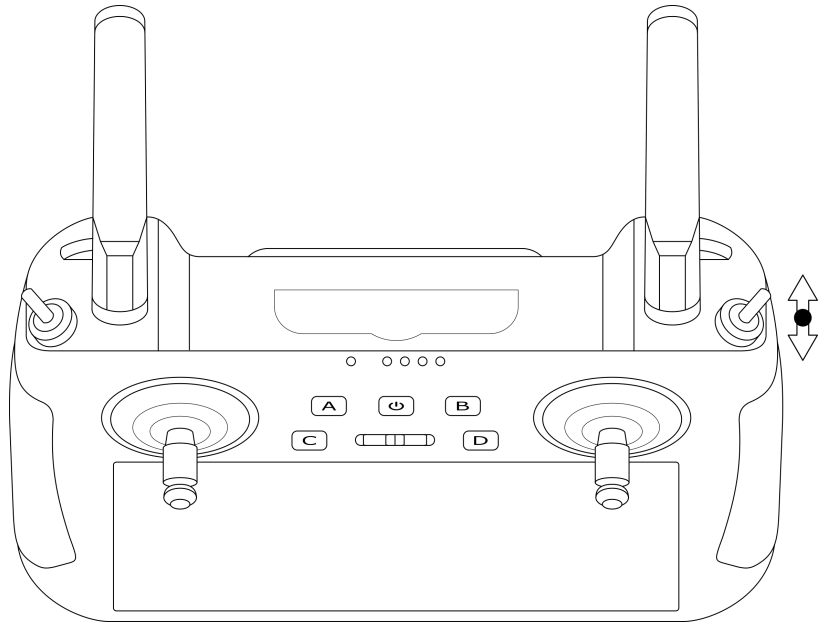

RTL (Return to Launch)

Returns the Surfbee to its armed position. It will also RTL when the lowest battery level is reached or if radio transmission is lost for 5 seconds.

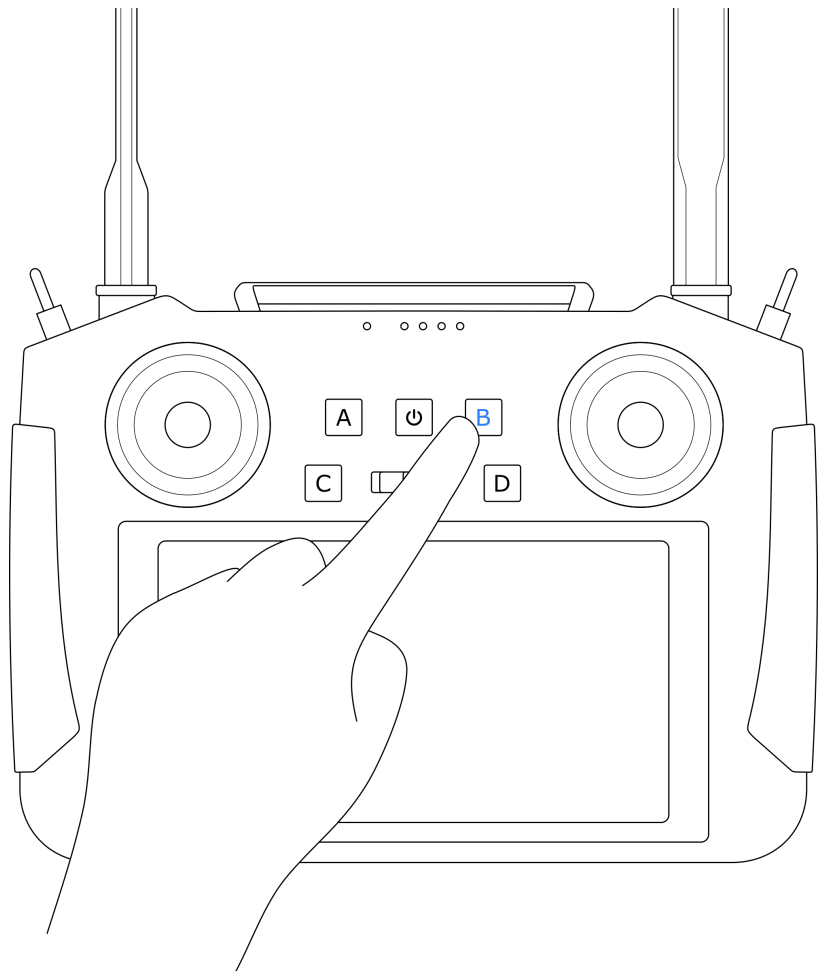

Manual Mode

Allows the operator to control the Surfbee using joysticks.

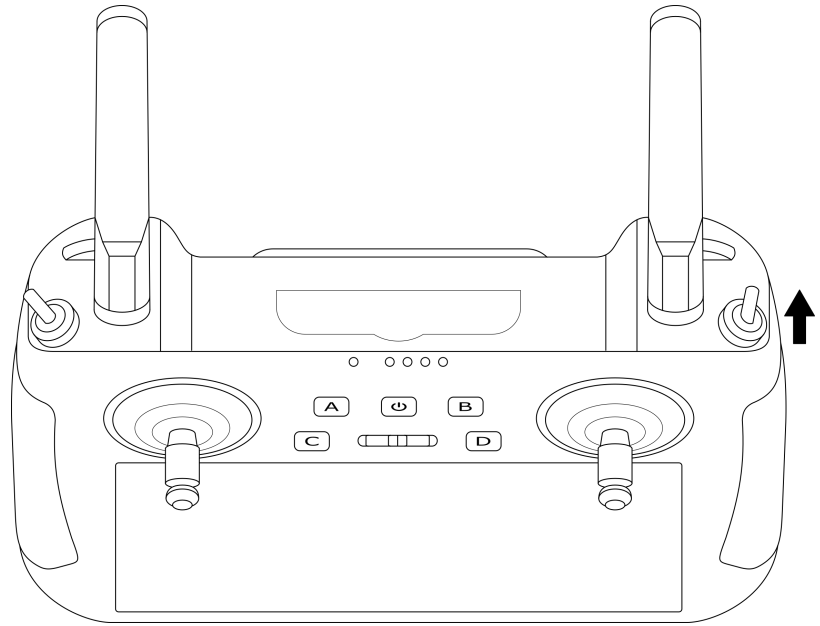

AUX Button

Secondary form of steering if a thruster is disabled, activating the APU (Auxiliary Propulsion Unit). Use for emergencies only and limit to 5 minutes of continuous use to prevent overheating.

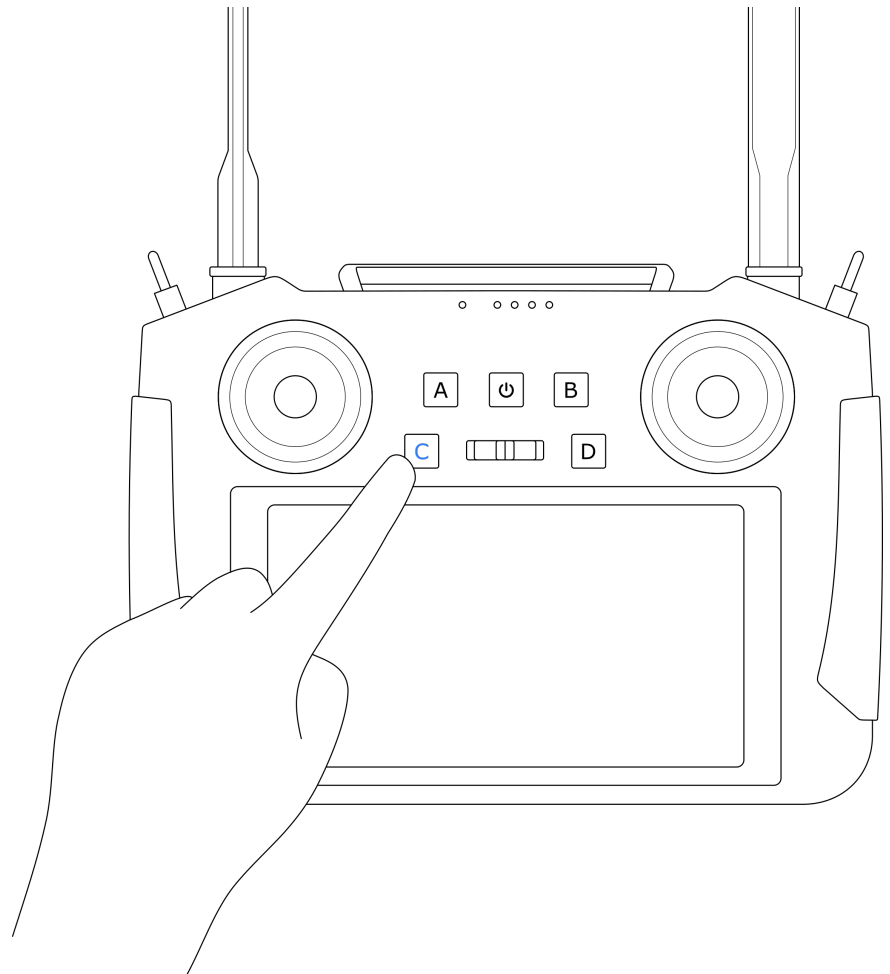

Light Button

Forward looking Light
illuminates on Mast Camera.

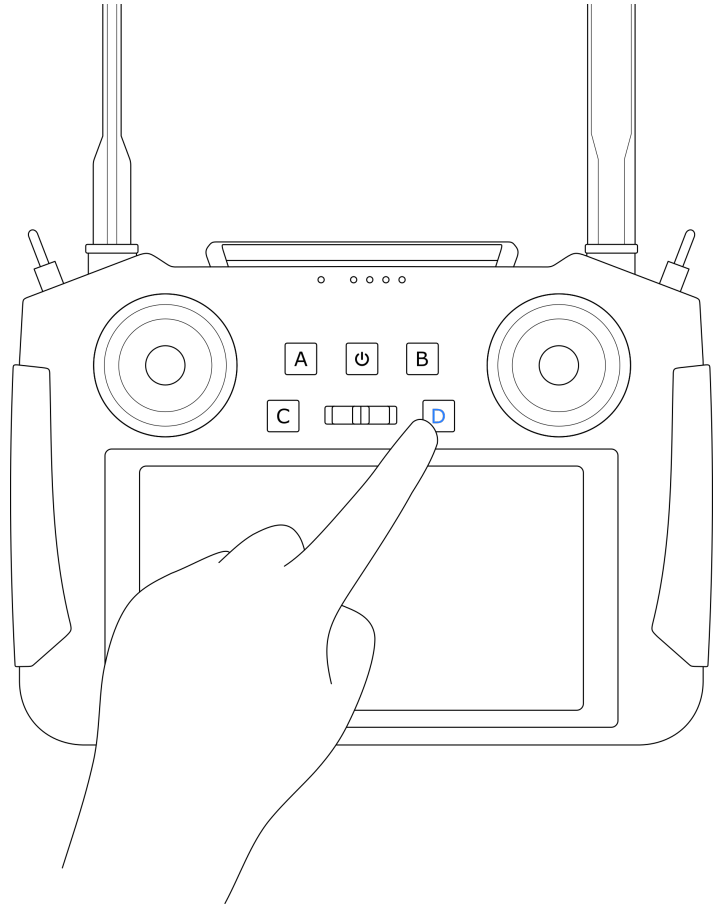

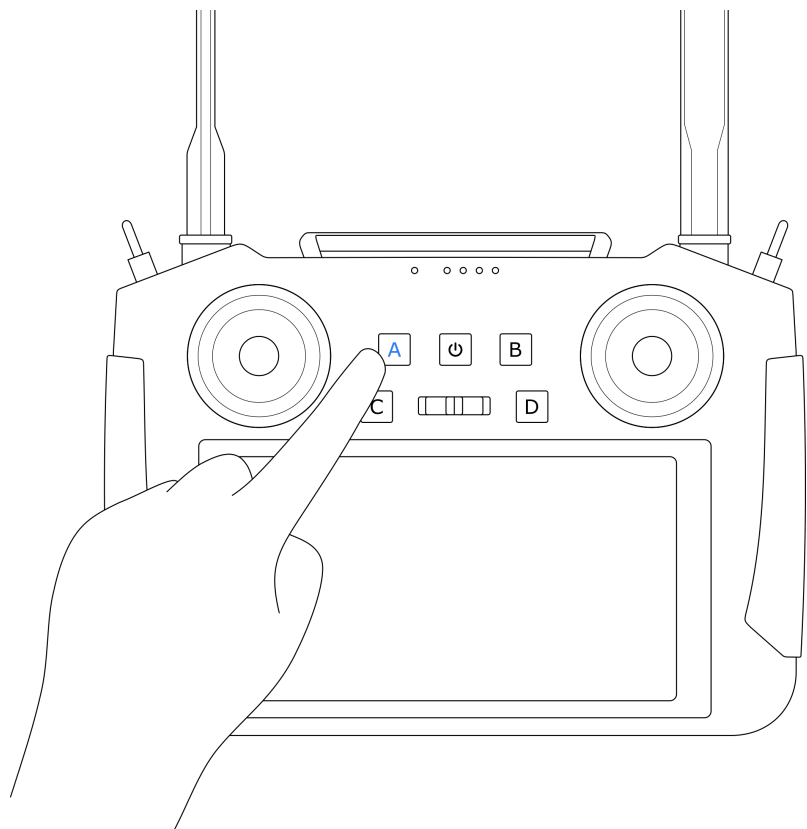

Simple Button

Switches configuration of
control to allow a simple
operating experience for
inexperienced operators.

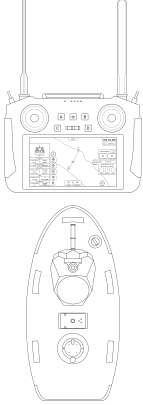
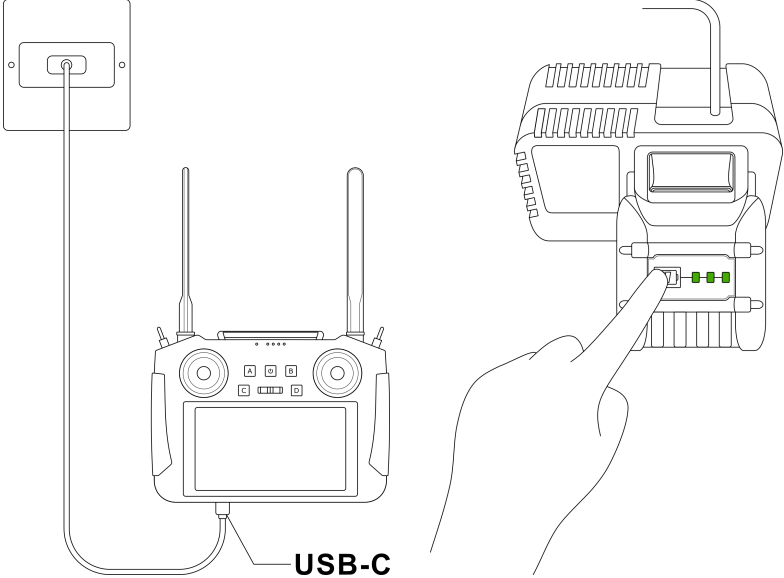

Launch Checklist

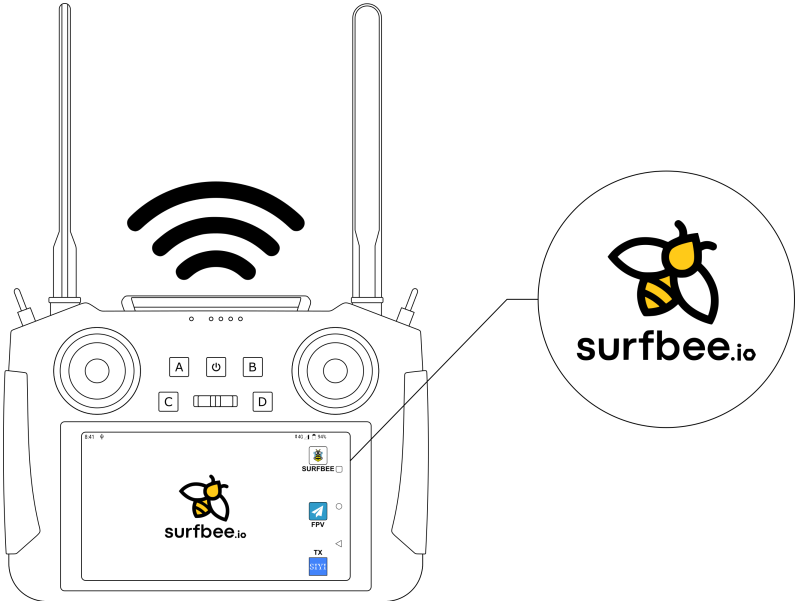
WHAT?	WHERE?	HOW?
<p>Preparation</p> <p>Ensure Surfbee DeWalt batteries and controller are fully charged</p>		<p>Ensure Surfbee DeWalt batteries and controller are fully charged.</p>  <p>USB-C</p>
<p>Ensure Surfbee App is updated to the latest version and has connectivity for real-time maps</p>		<p>Request the latest version of the Surfbee App to our team via email to: support@surfbee.zohodesk.com.au For more information, check our Surfbee App Manual.</p> 

WHAT?

WHERE?

HOW?

On-Site Setup

Fit Thrusters and Sensor



Securely attach thrusters to the underside mounts of the Surfbee in the correct Left (Blue marker to Blue locking nut) and Right configuration.

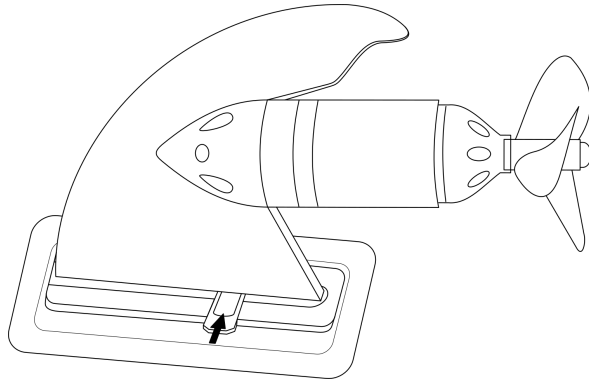
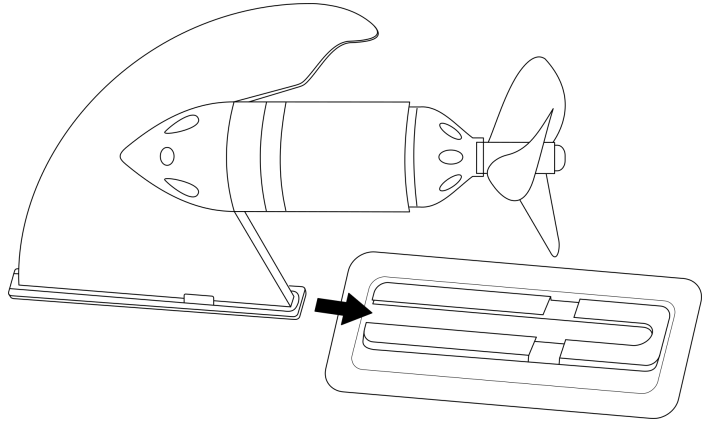

Insert the sensor into the locking collar and check that the height is suitable for the application, then tighten the locking collar with a 4mm allen key.

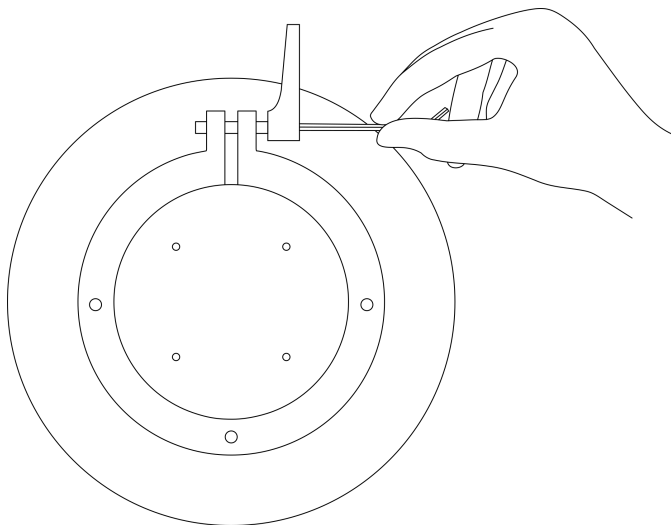

WHAT?

WHERE?

HOW?

Install Fully Charged Batteries



Insert the fully charged DeWalt batteries into the Surfbee. Please ensure Hatch is closed before operation.

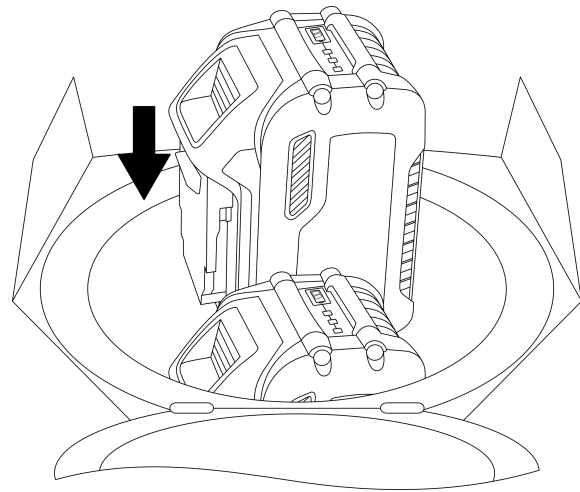
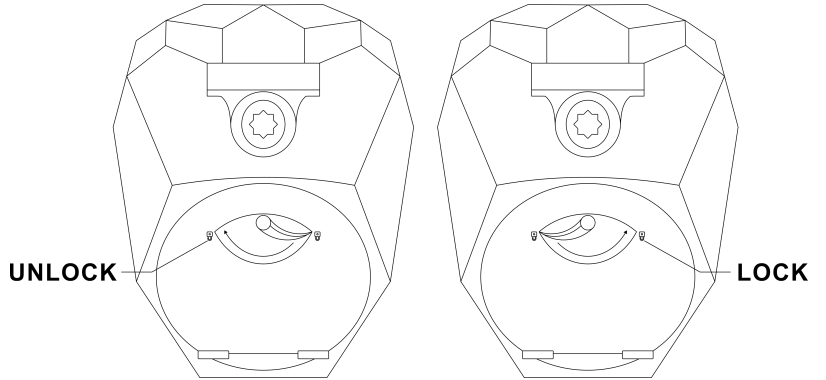

Switch to Disarm Mode



Set the Surfbee to **Disarm** mode on the controller (top-left switch) and **Manual** (top-right switch).

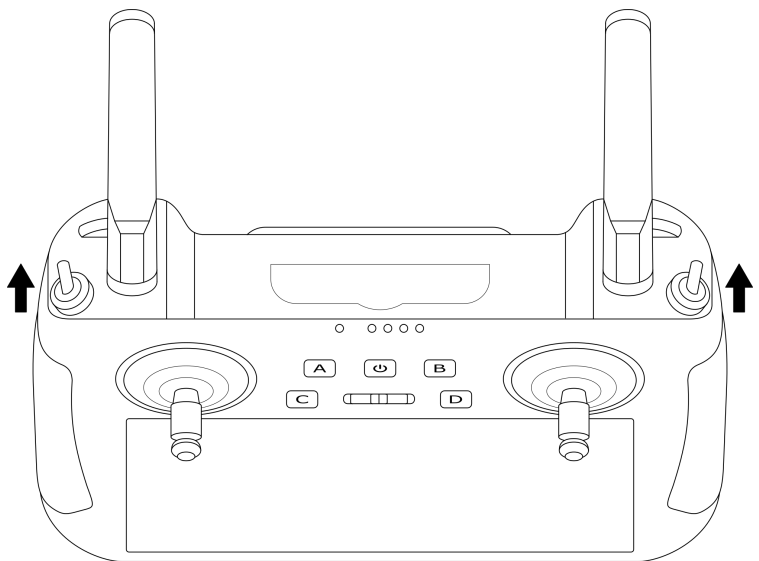

WHAT?

WHERE?

HOW?

Place the vessel onto level ground with a clear view of the sky



Set up the Surfbee on level ground with a good view of the sky, which aids in obtaining GPS lock.

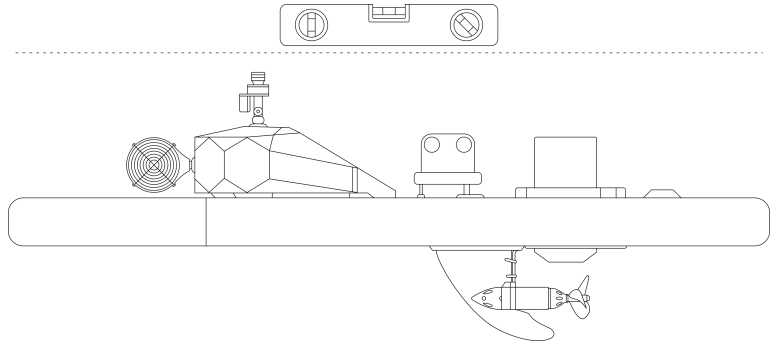

Power on the vessel using the locating magnet over the power location



Use the locating magnet to power on the Surfbee by placing it over the designated power location.

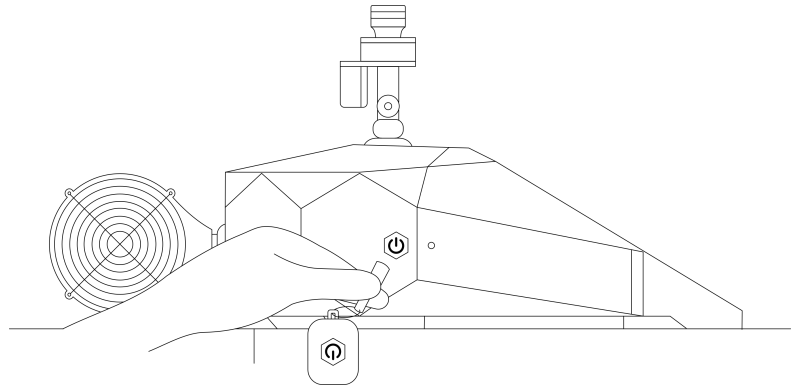

Wait for 90 seconds (mast LED should be blinking) before moving the vessel to the water



Allow at least 90 seconds for the Surfbee to acquire a GPS lock.

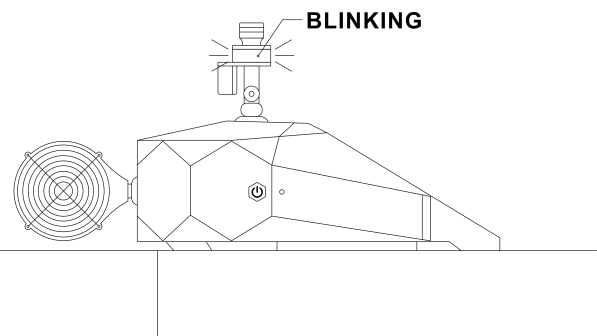

WHAT?

WHERE?

HOW?

Controller Setup

Press the power button on the controller once for 1 second and then again for 2 seconds until all power lights are illuminated



Power on the controller by pressing the button as instructed.

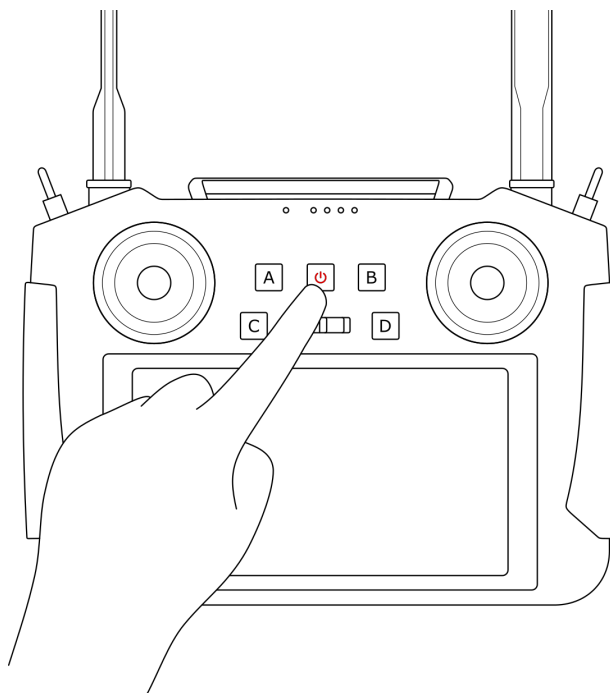

Once the controller has booted up, the Connection status LED will turn green once connected to the Surfbee



Wait for the green indicator on the controller to confirm successful connection to the Surfbee.

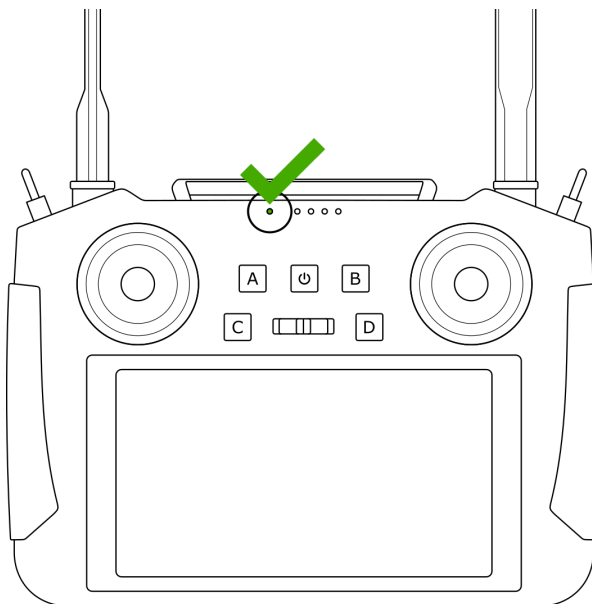

WHAT?

WHERE?

HOW?

Surfbee App Setup

Ensure the Surfbee mode is in Manual mode and is Disarmed



Verify that the Surfbee is in manual mode and disarmed on the controller. (Not essential but best practice).

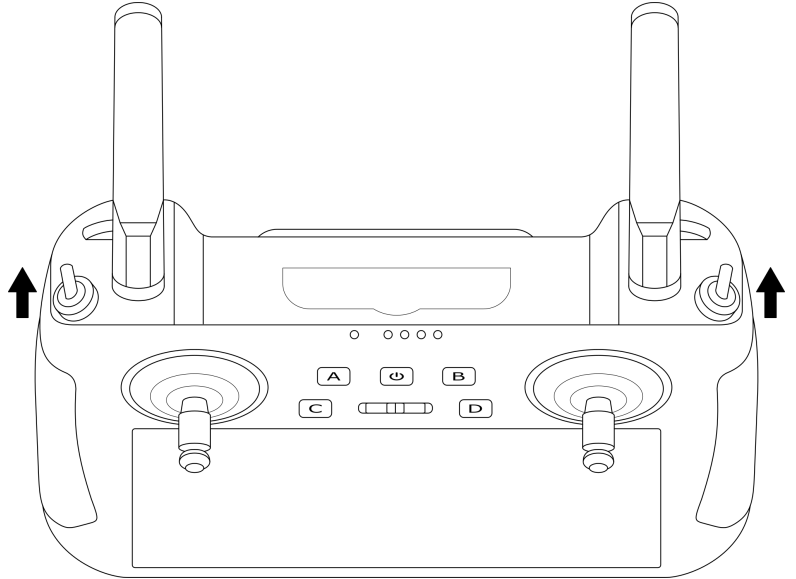

Launch the Surfbee app



Open the Surfbee app from the startup screen (top right corner) on the controller.

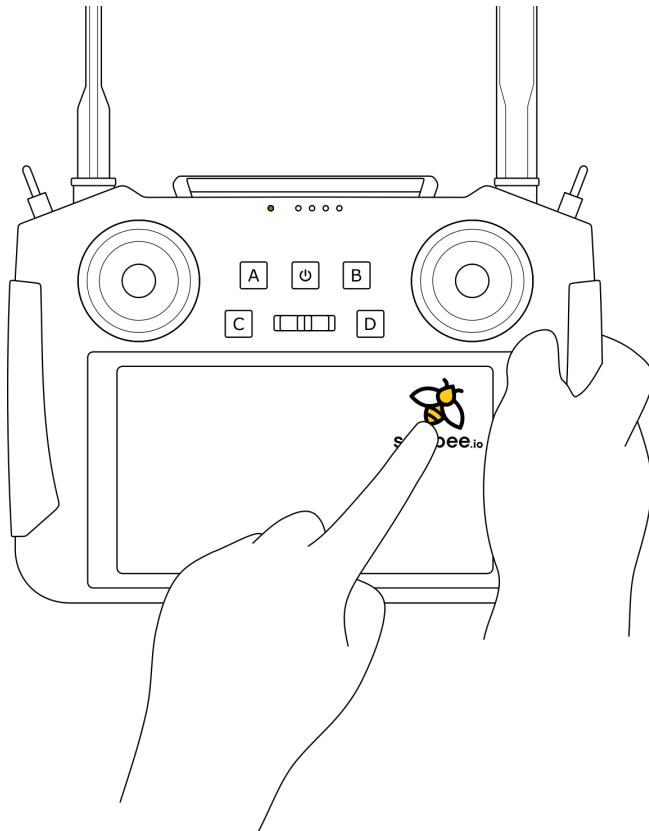

WHAT?

WHERE?

HOW?

Select the Connect button on the App to get Surfbee telemetry data



Use the app to connect to the Surfbee and access telemetry data.

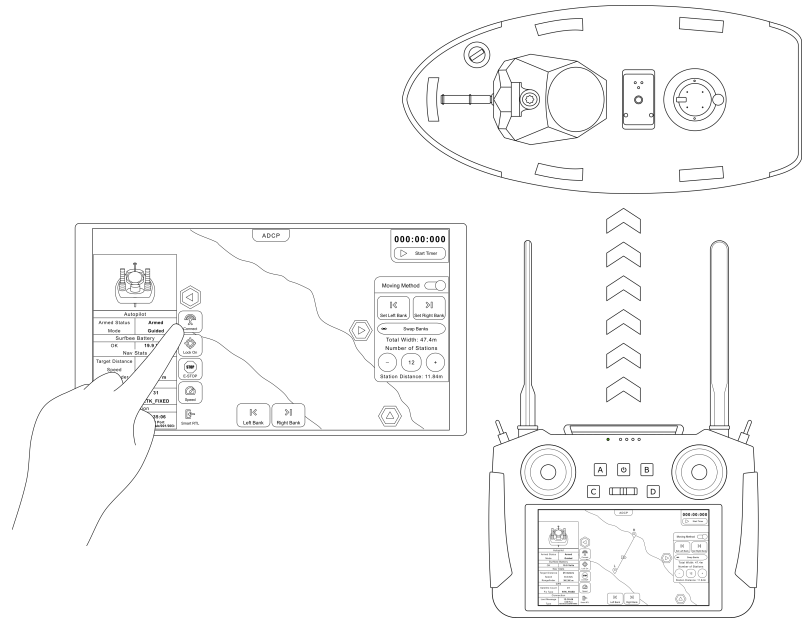

Launching

LED mast light on Surfbee flashing



Confirm that the LED mast light is flashing, indicating that the Surfbee is in a disarmed state.

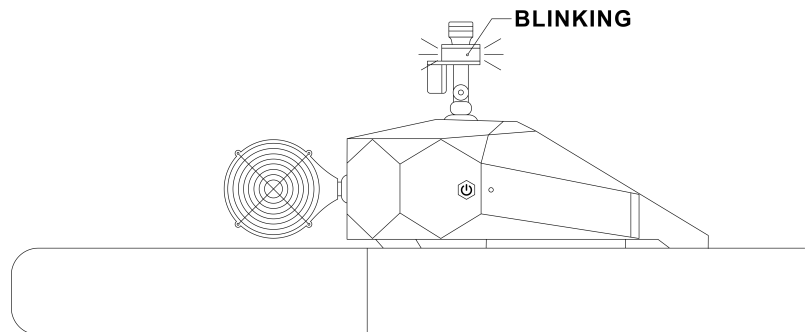

Portage to Launch



Move Surfbee to water using hand hold straps.

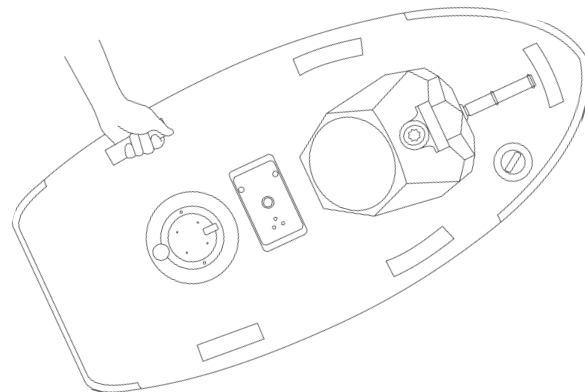

WHAT?

WHERE?

HOW?

Arming



Switch the A/D switch on the controller to the **Armed** position (move switch to most forward position) on the controller.

Important: Ensure props are clear of any obstructions, e.g., fingers, debris.

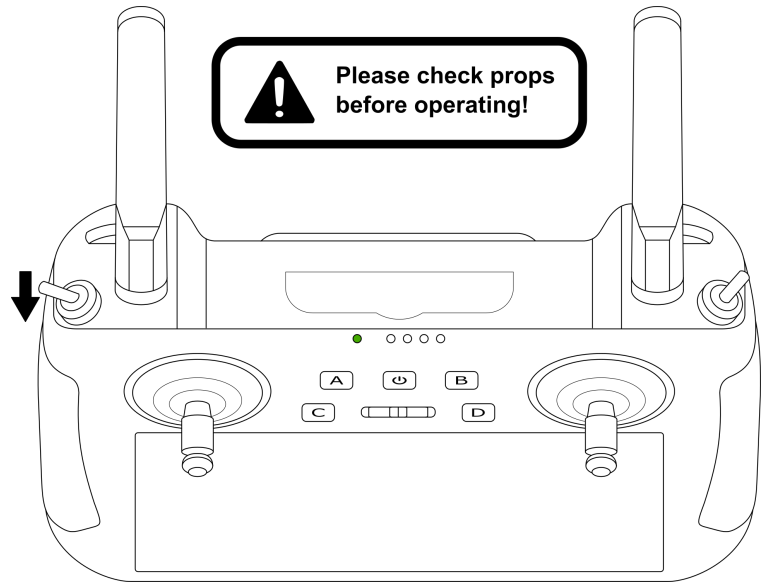

Confirm Armed

Reminder: Location of Return to Launch is set when Armed.



LED mast light will be Solid on Surfbee, and Armed Status on App.

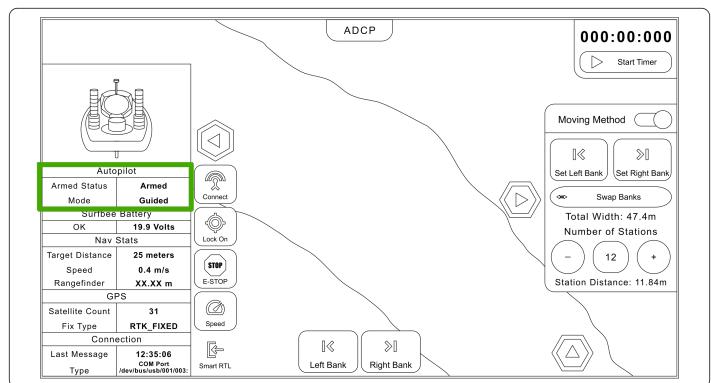
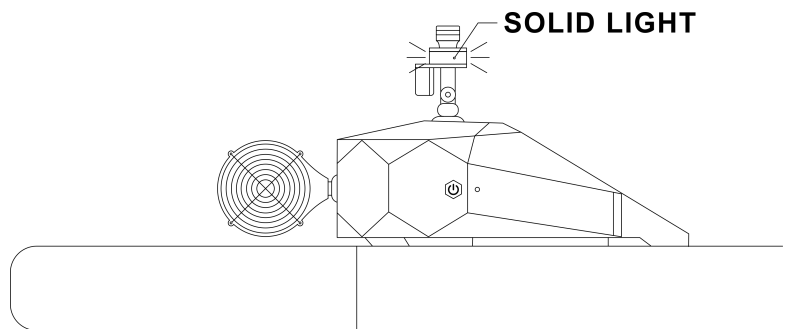

WHAT?

WHERE?

HOW?

Mission Ready

Now the vessel is ready for use

*Please refer to app manuals for ADCP Gauging, Bathymetry or Environmental Survey (including winching and water quality collection) operations.



With the Surfbee armed and all systems functioning, it is now ready to start the gauging/survey mission.

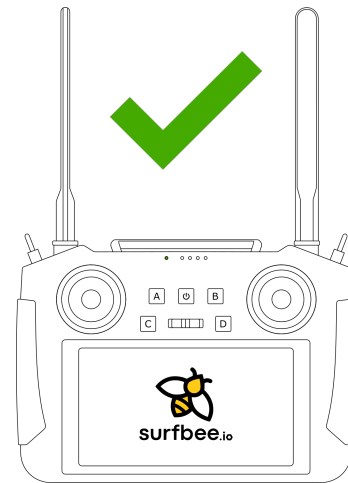
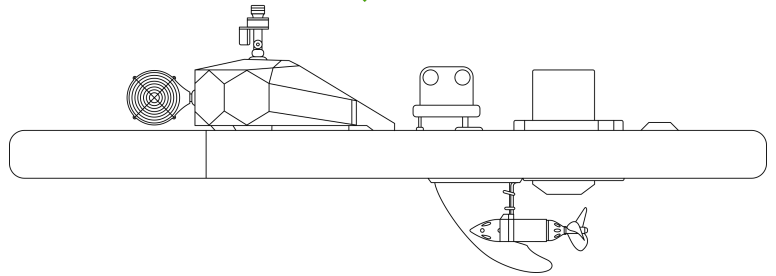

Shutdown Procedure

Return the vessel to a safe location



Navigate the Surfbee back to a safe and accessible location on the water.

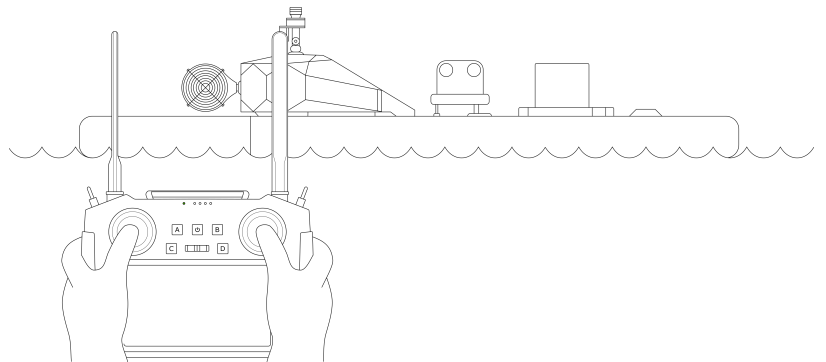

WHAT?

WHERE?

HOW?

Toggle the A/D switch to Disarm position



Switch the A/D switch on the controller to the **Disarm** position.

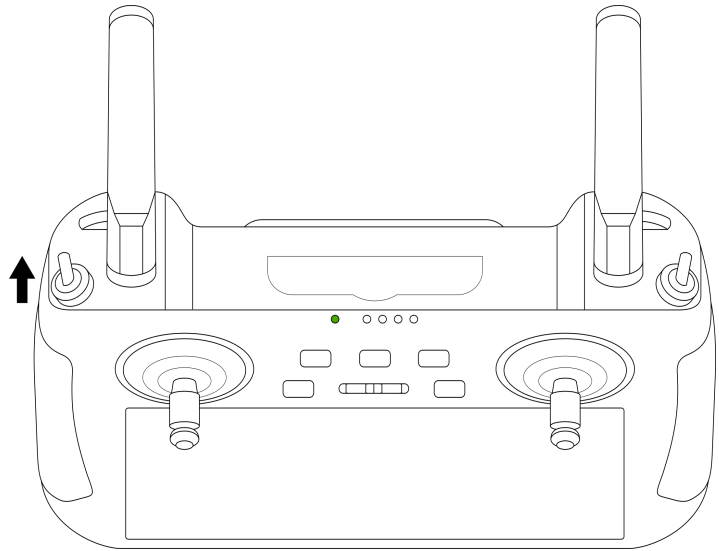

Power off the Controller

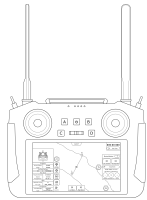

Press and hold the power button on the controller to power it off.

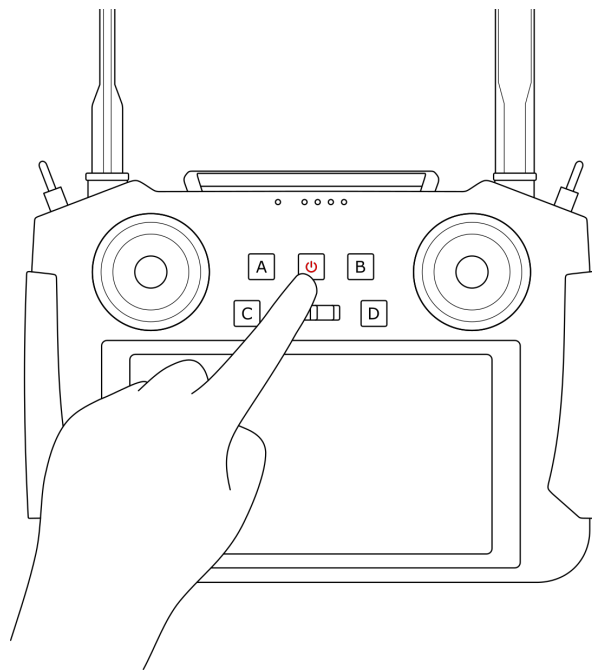

Power off the vessel using the locating magnet over the power location



Use the locating magnet to power off the Surfbee by placing it over the designated power location.

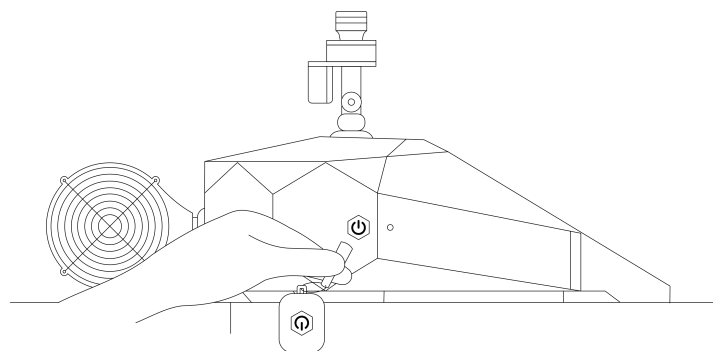

WHAT?

WHERE?

HOW?

Disconnect and remove DeWalt batteries



Remove the DeWalt batteries from the Surfbee.

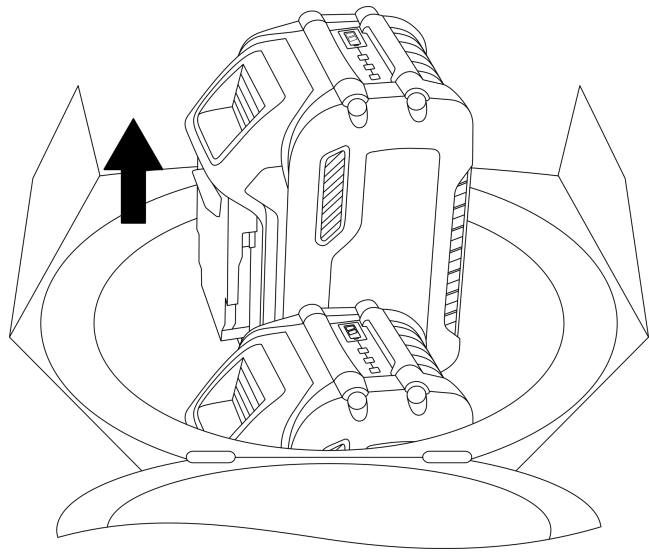

Remove Thruster Fins and Sensor



Carefully detach the thruster fins and transducer from the Surfbee.

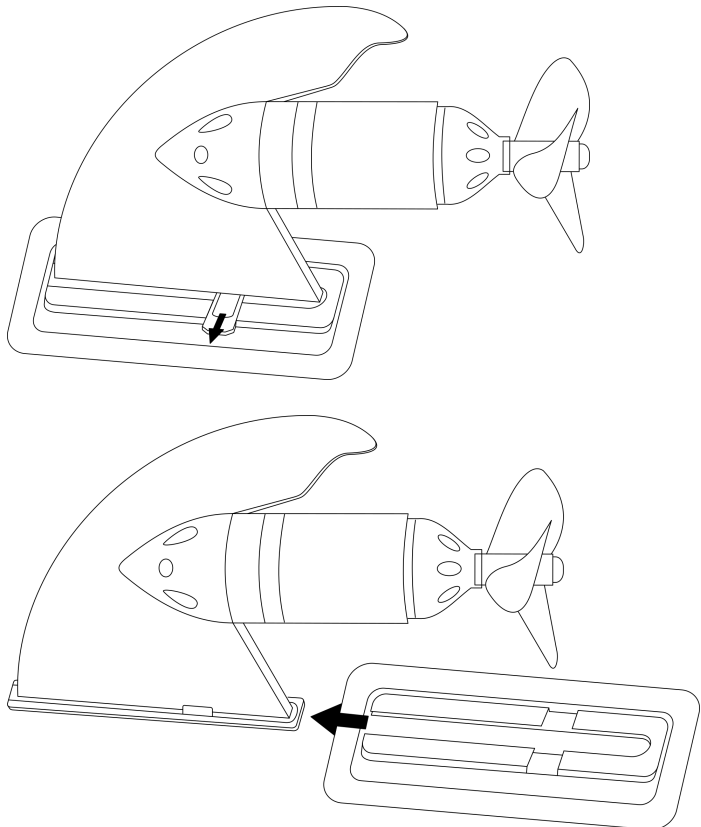

WHAT?

WHERE?

HOW?

Clean and dry the Surfbee



Flush (run in fresh water for 2 min) after use if operating in salt or highly turbid water.

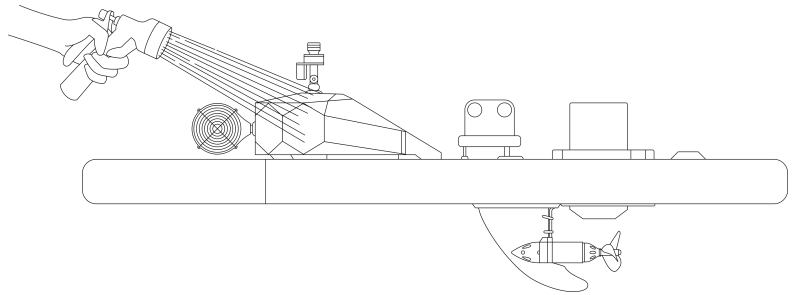

Store the Surfbee and Controller in a safe place



Place the clean and dry Surfbee and Controller in a secure storage location.

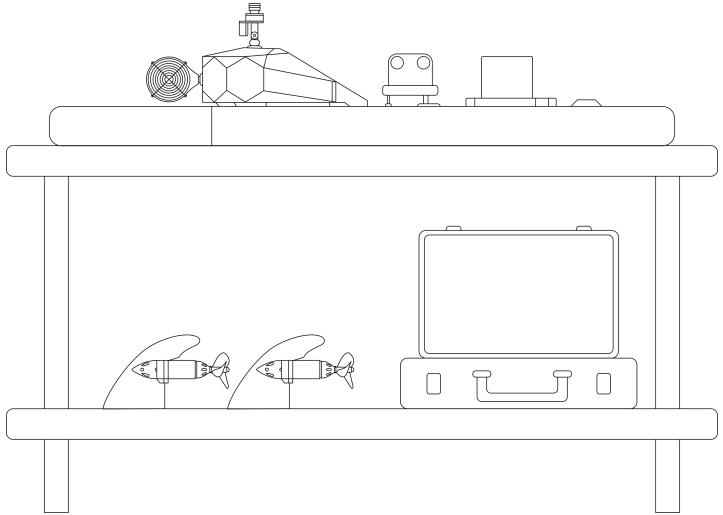

Charge Controller battery



Charge the controller batteries to ensure they are ready for the next use.

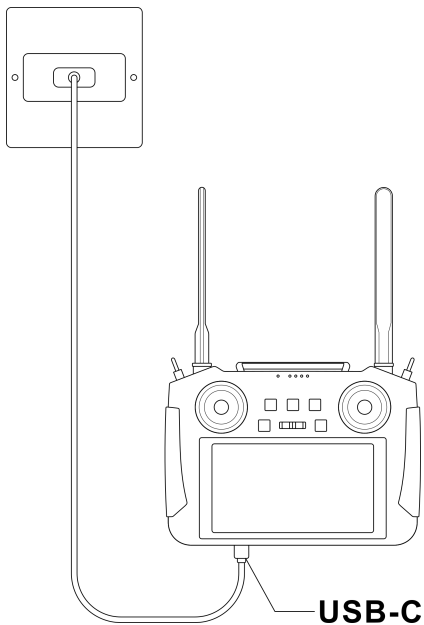

WHAT?

WHERE?

HOW?

Charge Surfbee
DeWalt batteries



Charge the Surfbee batteries to ensure they are ready for the next use.

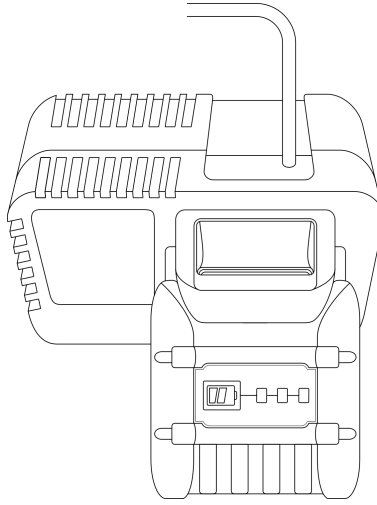

Warranty Information

Warranty

- a. **Manufacturer's Warranty:** Thruster, Hull, and Electronic Hardware.
- b. **Duration:** The warranty coverage for the Thruster, Hull, and Electronic Hardware is valid for a period of 6 months from the date of purchase.
- c. **Coverage:** This warranty covers defects in materials and workmanship under normal use and service. If a product is found to be defective in material or workmanship during the warranty period, it will be repaired or replaced at the manufacturer's discretion.
- d. **Exclusions:** Misuse by Customer: The warranty does not cover damages or defects arising from: Improper use or installation, Use of the product for purposes other than its intended function, Impact damages, such as dropping or colliding the product with another object, Overloading or using the product in a manner inconsistent with its specifications, Environmental Factors: Damage caused by exposure to extreme temperatures, corrosive environments, water ingress (unless the product is specifically designed to be waterproof), or UV damage is not covered, Unauthorised Repairs/Modifications: Any alterations, modifications, or repairs not authorized by the manufacturer will void the warranty.
- e. **Normal Wear and Tear:** The warranty does not cover cosmetic damages or damages resulting from normal wear and tear.
- f. Batteries are excluded from warranty.